

M.Sc. THESIS

**HYDRAULIC SIMULATION FOR FLOW OVER DOMELI
DAM SPILLWAY USING CFD MODEL**



ADVISOR

PROF. DR. HABIB UR REHMAN

SUBMITTED BY:

MUHAMMAD HARIS ASGHAR KHAN
2016-MS-WRE-09

CENTRE OF EXCELLENCE IN WATER RESOURCES ENGINEERING
University of Engineering and Technology, Lahore Pakistan

2020

ABSTRACT

Spillway is one of the important structures in dam that ensures the safe removal of flood water towards the downstream. The excessive water is transferred through spillway so that the dam can be preserved through overtopping and controls the flow. Spillway can be a part of a dam or can be provided separately depending upon the site conditions for the dam construction. Regime of flow in spillway is sub-critical at upstream and super-critical at the face. As the flow conditions are rapidly varied in the spillway so it is difficult to check the hydraulic conditions of the spillway. In spillway design, the discharge capacity should be properly investigated as it is the main reason for the failure of the dam's spillway.

Small dams are an important source of both primary and productive water for rural communities. Domeli dam is one of the small dam situated in Punjab province of Pakistan, which was designed against flood of 1185 cumecs. Unfortunately, dam's spillway was failed and its chute and stilling basin were severely damaged/washed away in 2015. In 2015 a severe flood of 1427 cumecs was reported through investigation of past flood marks. It was learnt that there was an obstruction on downstream of the stilling basin, which might have caused the backwater flow, whirlpool etc. due to which shear stresses might have gone beyond the permissible limit. Domeli Dam spillway severely damaged due to any of the following reasons: high discharge of 1427 cumecs whereas its capacity was 1185 cumecs, hydraulic shear stresses, downstream obstruction, poor energy dissipation system and cavitation problem. So, there was a need to investigate the flow parameters over the Domeli dam spillway to investigate the most likely cause of the failure.

In the present study, the flow characteristics of Domeli dam spillway were investigated using CFD modelling. The engineering drawings have been converted into 3 dimensional drawings for the preparation of geometry in the model. These 3-dimensional solid objects have been converted into stereo lithography files (.stl) which have been used as geometry files in Flow-3D model. Once the data has been incorporated, Validation of software was carried out.

Flow-3D was well validated for flow depths as the difference between simulated and observed values calculated to be 8.5%. Computational fluid dynamics model had successfully estimated the flow characteristics of Domeli dam spillway and is recommended for future similar studies. Also, the energy dissipation system was found adequate as Froude number decreased significantly over the spillway and about 70% of energy was dissipated which is efficient enough.

ACKNOWLEDGEMENTS

All praises and admirations are for Allah (SWT), who is bounteous and merciful and whose care and guidance led all of us to complete this ample task. And peace be upon Prophet Muhammad (SAW) who is a torch of guidance and knowledge for humanity forever.

I would like to express his sincere gratitude to Research Advisor Prof. Dr. Habib ur Rehman for his vigilant supervision, intellectual guidance, constructive advice and very kind attitude throughout the thesis. His compact and dense grip on the subject has always been inspiring for me. His directions assisted me to perform the broad-spectrum task in the square and conducive environment. I am indebted for his inclusive guidance. I am also thankful to Prof. Dr. Noor Muhammad Khan, Director, Centre of Excellence for providing excellent academic and research environment.

Last but not least, I am thankful to my parents, family members and friends who really believed in myself throughout my stay in this university and in the completion of this thesis.

Muhammad Haris Asghar Khan

DEDICATED

TO

MY BELOVED PARENTS

TABLE OF CONTENTS

Chapter No.	Description	Page #
	ABSTRACT	iii
	ACKNOWLEDGEMENTS	v
	TABLE OF CONTENTS	vii
	LIST OF FIGURES	ix
	LIST OF TABLES	xi
	LIST OF ABBREVIATIONS	xii
I.	INTRODUCTION	1
1.1	GENERAL	1
1.2	PROBLEM STATEMENT	1
1.3	OBJECTIVES OF THE STUDY	3
1.4	SCOPE OF THE STUDY	3
1.5	THESIS ORGANIZATION.....	4
II.	LITERATURE REVIEW	5
2.1	INTRODUCTION	5
2.2	INTRODUCTION TO SPILLWAY	5
2.3	TYPES OF SPILLWAY	6
2.4	STILLING BASIN.....	11
2.5	DOMELI DAM SPILLWAY	13
2.6	INTRODUCTION TO CFD MODEL	13
2.7	FLOW 3D MODEL	14
	2.5.1 Basic Concept	14
	2.5.2 Governing Equations	15
2.8	PAST STUDIES ON FLOW-3D	18
2.9	SUMMARY	25
III.	METHODOLOGY	26
3.1	INTRODUCTION	26
3.2	DATA COLLECTION	27
	3.2.1 Maximum instantaneous discharge.....	27
	3.2.2 Longitudinal section.....	27
	3.2.3 Spillway design details	29
3.3	DATA ANALYSIS.....	29
	3.3.1 Rainfall Frequency analysis.....	29
	3.3.2 Flood estimation using HEC-HMS	30

Table of Contents (Continued)

3.4	CFD MODEL SETUP	31
3.4.1	Modelling Assumptions	31
3.4.2	Setting up of Flow-3D model	32
3.4.3	Numerical model setup	33
3.4.4	Model application	36
3.5	SENSITIVITY ANALYSIS	37
3.5.1	Approach.....	37
IV.	RESULTS & DISCUSSION	38
4.1	INTRODUCTION	38
4.2	RAINFALL FREQUENCY ANALYSIS	38
4.3	FLOOD FREQUENCY ANALYSIS	40
4.4	CALIBRATION OF HEC-HMS	41
4.5	VALIDATION OF FLOW-3D MODEL.....	42
4.6	SENSITIVITY ANALYSIS	43
4.7	ASSESSMENT OF FLOW CHARACTERISTICS	45
4.7.1	Flow depth	45
4.7.2	Velocities	46
4.7.3	Pressure	50
4.7.4	Turbulence Models	50
4.7.5	Bed Shear Stresses	51
4.7.6	Cavitation.....	52
4.8	PERFORMANCE OF ENERGY DISSIPATION.....	53
V.	CONCLUSIONS & RECOMMENDATIONS	55
5.1	INTRODUCTION	55
5.2	CONCLUSIONS.....	55
5.3	RECOMMENDATIONS	56
5.4	FUTURE RECOMMENDATIONS	56
	REFERENCES	57

LIST OF FIGURES

Figure No.	Description	Page #
1.1	Broken Stilling Basin of Domeli Dam.....	2
1.2	Broken Stilling Basin of Domeli Dam.....	3
2.1	Spillway of Mangla Dam	6
2.2	Free Over-Fall Spillway of an Arch Dam.....	7
2.3	Ogee Spillway of Sardar Sarovar Dam	8
2.4	Chute Spillway	8
2.5	Side Channel Spillway	9
2.6	Shaft Spillway	10
2.7	Tunnel Spillway with a Morning Glory Entrance.....	10
2.8	Siphon Spillway	11
2.9	Stilling Basin USBR Type III.....	12
2.10	Stilling Basin Performance (2000 cumecs).....	18
2.11	Geometry of Guide Wall.....	19
2.12	Head Values	20
2.13	Velocity vs. Distance	20
2.14	Different USBR Types.....	21
2.15	Flow Patterns	22
2.16	Flow Patterns at Flood Levels.....	22
2.17	Physical Model Values	23
3.1	Flow Chart of the Methodology.....	26
3.2	L-Section of Domeli Dam Spillway	28
3.3	Domeli Dam spillway Layout Plan.....	28
3.4	Time Series of One Day Maximum Rainfall	30
3.5	Flood Estimation using HEC-HMS	31

3.6	Geometry of Spillway	33
3.7	Model Setup of Flow-3D	34
3.8	Mesh Geometry in Flow-3D	35
3.9	Boundary Condition in Flow-3D	35
4.1	Results of Rainfall Frequency Analysis.....	39
4.2	Estimation of Design Flood	40
4.3	Flood Frequency Analysis	41
4.4	Calibration of HEC-HMS	42
4.5	Validation of Flow-3D.....	43
4.6	Results of Sensitivity Analysis	44
4.7	Sensitivity Analysis at 1589 cumecs.....	44
4.8	Side View of Domeli Spillway	45
4.9	Flow Depths for Different Discharges	46
4.10	Velocities for Different Discharges	46
4.11	Velocity Contour at 1589 cumecs.....	47
4.12	Velocity Contour at 1448 cumecs.....	47
4.13	Velocity Contour at 1116 cumecs.....	48
4.14	Velocity Contour at 974.7 cumecs.....	48
4.15	Velocity Contour at 634.9 cumecs.....	49
4.16	Velocity Contour at 268.5 cumecs.....	49
4.17	Pressure Fluctuations	50
4.18	Cross Sectional View for Bed Shear Stresses.....	51
4.19	Longitudinal View for Bed Shear Stresses	52
4.20	Energy Dissipation.....	53
4.21	Energy Dissipation at 1589 cumecs.....	54

LIST OF TABLES

Table No.	Description	Page #
2.1	List of CFD Models	13
2.2	Average Physical Model Difference	24
3.1	Design Details of Domeli Spillway	29
3.2	Discharge Values	36
4.1	Rainfall Frequency Analysis.....	39
4.2	Turbulence Characteristics.....	51

Chapter I INTRODUCTION

1.1 GENERAL

Spillways are used to transfer extra or floodwater flows for storage dams which can not be contained in the allotted space. The surplus water is transferred from the top of the dam and forwarded again to the river through an artificial waterway. The flow at the spillway chutes is normally super-critical and velocities are very high at spillway chutes i.e. up to 50 m/s. These high velocities can erode the downstream river valley and destroy any structures downstream. These high velocities can also cause undermining of the spillway structure. The energy of water need to be dissipated and for this purpose energy dissipation systems are installed. Different energy dissipation systems are available, depending upon the differential head, site conditions, discharge etc. some of energy dissipaters are:

- i) Stilling Basin
- ii) Flip Bucket
- iii) Roller Bucket
- iv) Baffle Apron Spillway
- v) Stepped Spillway

1.2 PROBLEM STATEMENT

Domeli Dam spillway severely damaged due to high discharge of 1427 Cumecs whereas its capacity was 1185 Cumecs. Also, there was a rock mass in the downstream of the spillway, due to which the falling water stroked against the basin bed, broken the stilling basin slab, when eventually the blockage to spillway was

occurred and whirlpool phenomenon started. Eventually the spillway has been failed due to breakage of its stilling basin. Due to the above-mentioned reason there was a need to investigate the flow characteristics of Domeli dam spillway and its energy dissipation system (stilling basin). Figures 1.1 and 1.2 are showing the damaged spillway of Domeli dam. From these figures it can be seen clearly the stilling basin is severely damaged and broken and rehabilitation is needed.



Figure 1.1 Broken stilling basin of Domeli Dam



Figure 1.2 Broken stilling basin of Domeli Dam

1.3 OBJECTIVES OF THE STUDY

Following are the objectives set for the study:

- i. To estimate the design floods for Domeli Dam spillway.
- ii. To investigate the flow characteristics at different discharges over the spillway using CFD Model.
- iii. To carry out sensitivity analysis of the CFD Model against mesh size.
- iv. To check the hydraulic performance of energy dissipation system at various floods.

1.4 SCOPE OF THE STUDY

The research scope includes the implementation and simulation of the computational fluid dynamics model for spillway modeling as well as its energy dissipation me

thods. Rainfall frequency analysis and flood frequency analysis is also covered in this study along with the calibration of HEC-HMS and validation of Flow-3D model. The flow characteristics are checked for different discharges at different cross-sections and energy dissipation system is also checked using their Froude numbers. Sensitivity analysis of the model was also checked against standard, +20% and -20% mesh sizes.

1.5 THESIS ORGANIZATION

Chapter # 1: “Introduction” This chapter addresses the introduction, problem statement, Research objectives and scope of the study.

Chapter # 2: “Literature Review” This chapter covers the recent and past studies of the researchers related to the simulation of flow over spillway using 3-D model. Also, some literature regarding the Flow 3D model.

Chapter # 3: “Methodology” This chapter deals with spillway’s software-based research method. This chapter deals with the development of spillway geometry including spillway meshing, model initial boundary conditions, boundary conditions etc.

Chapter # 4: “Results & Discussion” This chapter shows the detail discussion regarding the CFD analysis. Model calibration & validation, sensitivity analysis.

Chapter # 5: “Conclusion & Recommendations” This chapter defines the overall conclusion of the conducted research, recommendation from the current research and recommendation for the future research.

Chapter II LITERATURE REVIEW

2.1 INTRODUCTION

This chapter explains the types of spillways and numerous dissipators of energy. The physical and numerical aspects of modeling were also explored. There were also various computational fluid dynamics models explored. This chapter addressed the Flow 3D model that is primarily used for this study. Previous research that was performed in Flow – 3D is also provided:

Previous research that was performed in Flow-3D is also provided.

2.2 INTRODUCTION TO SPILLWAY

Spillway is one of the important structures in dam that ensures the safe removal of flood water towards the downstream. The excessive water is transferred through spillway so that the dam can be preserved through overtopping and controls the flow. Spillway can be a part of a dam or can be separate from it depending upon the site selected for the dam construction. Regime of flow in spillway is sub-critical at upstream and super-critical at the face. As the flow conditions are rapidly varied in the spillway so it is difficult to check the hydraulic conditions of the spillway. In spillway design, the discharge capacity should be properly investigated as it is the main reason for the failure of the dam's spillway.

Spillway can be controlled or uncontrolled. If the spillway is provided with gates, then this type of spillway is known to be controlled spillway. Controlled spillway has an advantage that water level can be raised and lowered according to the

need. The other type is uncontrolled spillway which is provided without gates. Controlled spillway is more advantageous than uncontrolled as excessive water can be stored in it above its crest level due to gates.



Figure 2.1 Spillway of Mangla dam

2.3 TYPES OF SPILLWAY

There are several types of spillway which are used according to the site conditions and other parameters. The most commonly used one is Ogee-crested spillway due to its efficient hydraulic characteristics. Different types of spillways are listed as below:

- i. Free over-fall (Drop) spillway
- ii. Ogee (over-flow) spillway
- iii. Chute (open channel) spillway
- iv. Side channel spillway
- v. Shaft spillway

- vi. Tunnel spillway
- vii. Siphon spillway

i) Free over-fall (Drop) spillway

The water falls freely in this type of spillway. In this type of spillway, the crest is usually extended like an over-hanging lip. A decked overflow dam with a vertical or adverse inclined downstream face can also be provided (Hydraulic structures by Novak, 2017).

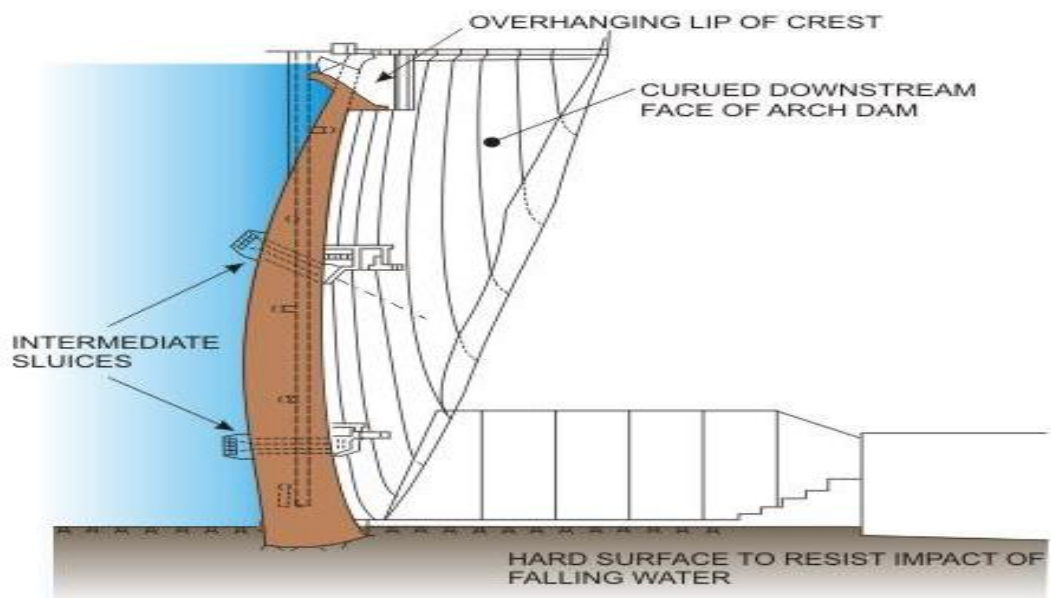

Figure 2.2 Free over-fall spillway of an arch dam

ii) Ogee (over-flow) spillway

This type is named after its shape which is like S- shape or ogee shape. Basically, shape of an ogee spillway is designed as of its lower nappe. For discharges at designed head, the spillway attains near-maximum efficiency. The profile of the spillway surface is continued in a tangent along a slope to support the sheet of flow on the face of the overflow (Hydraulic structures by Novak, 2017).

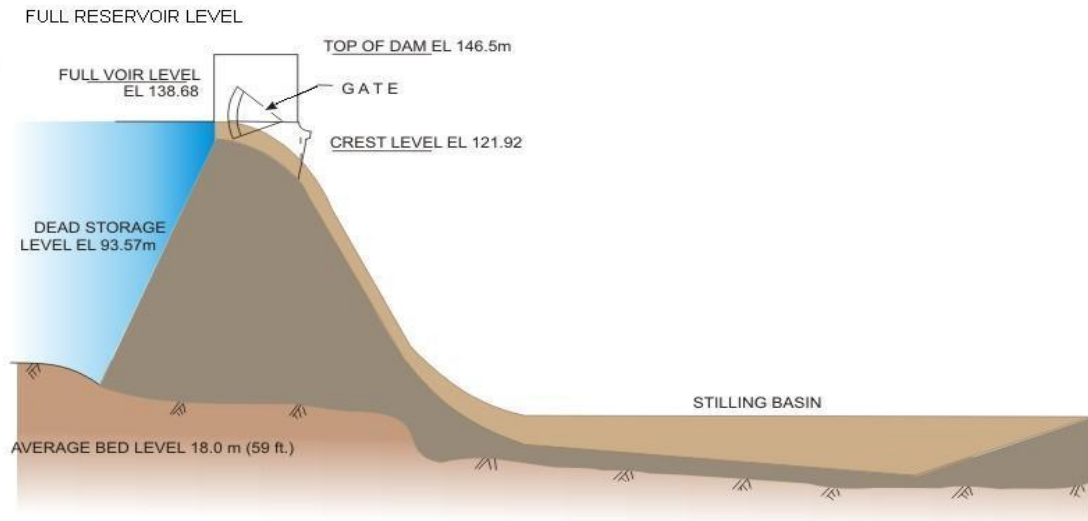

Figure 2.3 Ogee spillway of Sardar Sarovar Dam

iii) Chute (open channel) spillway

In this type of spillway, the discharge from the reservoir to the downstream is taken through an open channel constructed either along a saddle or through the dam abutment. Generally, the chute spillway has been mostly used in conjunction with embankment dams. Chute spillways ordinarily consist of an entrance channel, a control structure, a discharge channel, a terminal structure, and an outlet channel (Hydraulic structures by Novak, 2017).

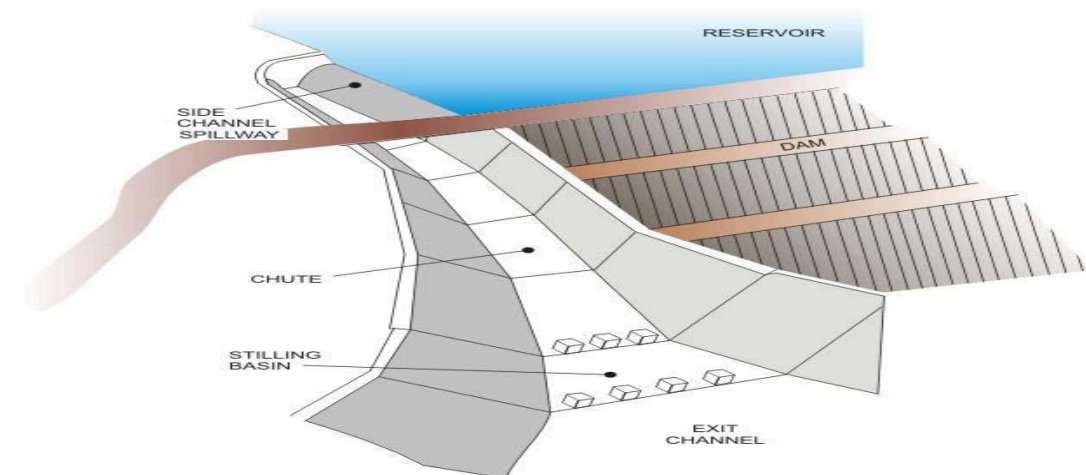

Figure 2.4 Chute spillway

iv) Side channel spillway

Side channel spillway is located on the upstream and just on the side of the dam. It is usually provided parallel to the crest of the dam. The flow through a side channel spillway is then carried by a chute or sometime by tunnel. (Hydraulic structures by Novak, 2017)

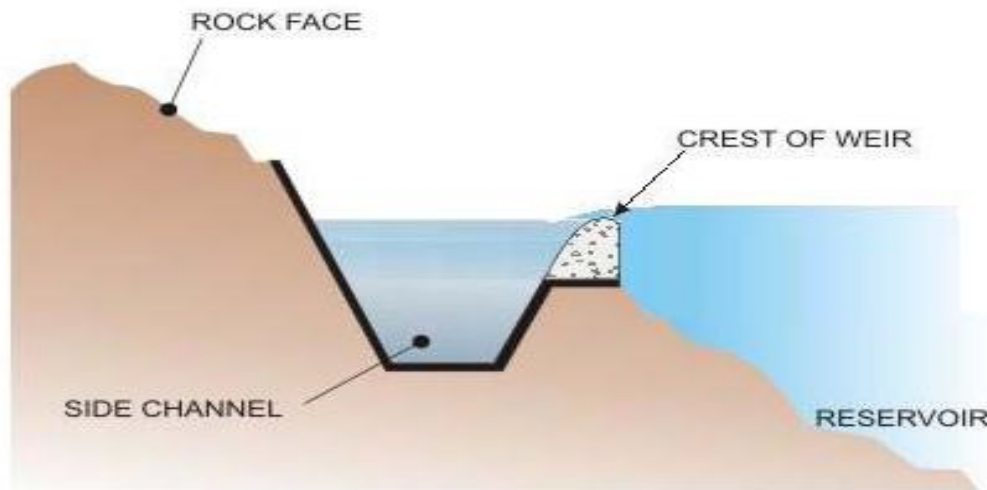

Figure 2.5 Side channel spillway

v) Shaft spillway

This type of spillway is also known as morning glory spillway. The water enters a horizontal tunnel through a vertical or sloping tunnel. These types of spillways usually attain maximum discharge at relatively low heads. At relatively low heads, this type of spillway achieves maximum discharge capacity. However, there is little capacity increase beyond the designed head if a flood exceeds the design of the selected flood. It may also be used in projects where there is a diversion tunnel or conduit (Hydraulic structures by Novak, 2017).



Figure 2.6 Shaft spillway

vi) Tunnel spillway

When the discharge is carried through the sides of the dam through a closed channel. These are advantageous in narrow gorges dam sites where there is danger of rock sliding from adjoining hills. The closed channel may take the form of a vertical or inclined shaft, a horizontal tunnel through earth or rock, or a duct constructed of earth materials in open cut and backfilled. Some types of control structures may be used for tunnel spillways, including overflow crests, vertical or inclined orifice openings, drop inlet entrances and side channel crests (Hydraulic structures by Novak, 2017).

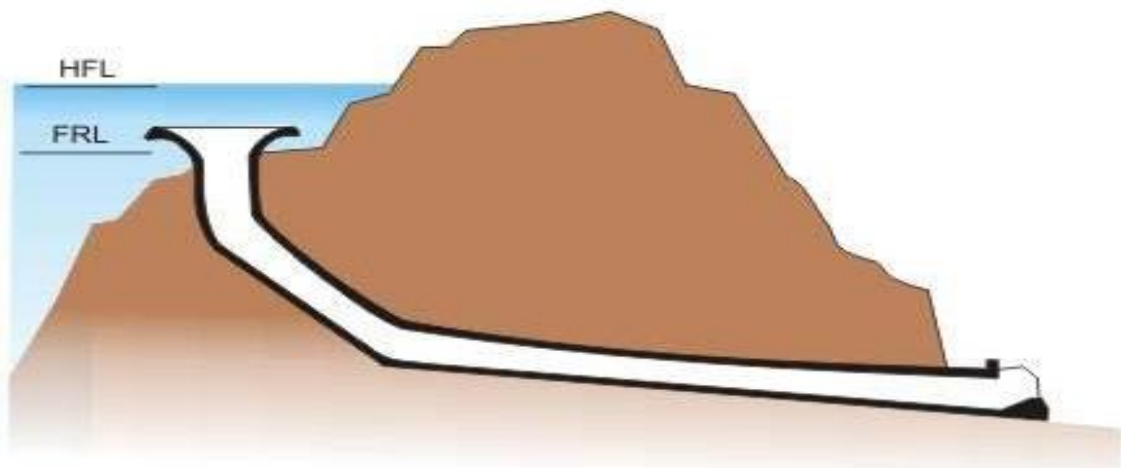

Figure 2.7 Tunnel spillway with a morning glory entrance

vii) Siphon spillway

Siphon spillways is designed in the formed of an inverted U and is closed conduit. The hood level in siphon spillway is greater than the reservoir level. A siphon breaker air vent is also provided to control the siphonic action of the spillway so that it will cease operation when the reservoir water surface is drawn down to normal level. Otherwise the siphon would continue to operate until air entered the inlet. The inlet is generally placed well below the Full Reservoir Level to prevent entrance of drifting materials and to avoid the formation of vortices and drawdowns which might break siphonic action. Hooded and Tilted outlet are two types siphon spillways. (Hydraulic structures by Novak, 2017)

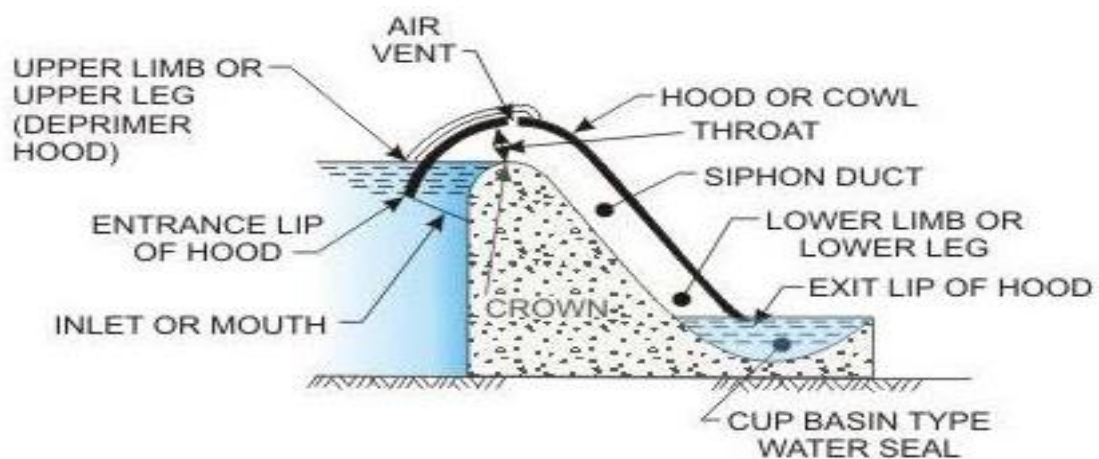

Figure 2.8 Siphon spillway

2.4 STILLING BASIN

Stilling basins are generally placed at the end of the spillway. There are various types of stilling basin that can either a straight drop or an inclined chute. Inclined chutes are the most common types and widely used in spillway considerations. The main elements of a stilling basin are as follow:

- i. Chute blocks
- ii. Baffle blocks
- iii. End sills

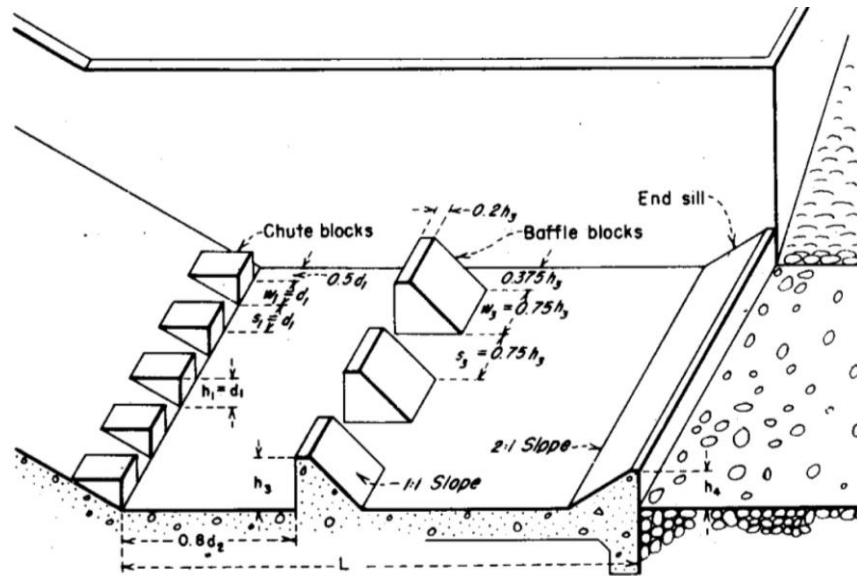

Figure 2.9 Stilling Basin USBR type III

The other types of inclined chute blocks are as follow:

- i. USBR type II stilling basin
- ii. USBR type III stilling basin
- iii. USBR type IV stilling basin

These are usually differentiated in the basis of different elements of stilling basins as listed above.

The spillway can be failed due to any of the following reasons:

- i. Erosion in the downstream channel.
- ii. Erosion of toe of embankment dam.
- iii. Erosion of stilling basin foundation
- iv. Uplift pressure
- v. Ultimate failure of stilling basin

2.5 DOMELI DAM SPILLWAY

Spillway is a long chute of concrete and a stilling basin. The chute is about 240 ft. long and 230 ft. wide. The stilling basin is 112 ft. x 230 ft.

Domeli dam spillway has following characteristics:

Location: Easting: 343612.28 m Northing: 3654742.49 m

Type of Spillway: Chute Spillway

Crest Elevation: 1175 ft. amsl

Width of Spillway: 230 ft.

Energy Dissipation: Hydraulic Jump at the D/S glacis and a Stilling Basin

2.6 INTRODUCTION TO CFD MODEL

Physical analysis has been used for years for the computation of flow characteristics in hydraulic structures especially in spillways. But with the advancement in computer power and modelling facility it has now become feasible to use numerical models (three-dimensional analysis) which are easier, cheaper, faster and effective in use. There are different numerical models available for the analysis of hydraulics which can be either free or commercially paid. Following are different CFD models:

Table 2.1 List of CFD models

1 Dimensional CFD Model	FMS-1D, ISIS-CFD
2 Dimensional CFD Models	HYDRO, NSC2KE, NaSt2D
3 Dimensional CFD Model	STAR – CD, FLOW 3D, CFX, SSIIM, Fluent

Flow-3D is used in this research for hydraulic analysis due to following reasons:

- i. CFD model is capable of modeling complex hydraulics.
- ii. CFD model is easy to set-up with rigid solid files.

2.7 FLOW 3D MODEL

The fluid flow problems are analyzed by the Computational Fluid Dynamics (CFD) which is a numerical modelling method. In this thesis Flow-3D model is used which is a CFD model and is widely used now-a-days. Flow-3D is a latest and powerful software that can solve the fluid flow problems easily and efficiently. Flow-3d software allows either solve a one or two fluid flow, including free surface or not. Different meshing and geometry options are included in this software. In Flow-3D different simple objects can be made and also the complex geometry objects can be imported through different software. Also, wide variety of boundary conditions can be introduced in it. CFD model is capable of modeling complex hydraulics. CFD model is easy to set-up with rigid solid files. CFD model allows the modelling of fluid flow in complex geometry. Flow-3d is also graphically user interface. It also provides the special capabilities for accurate prediction for free-surface flows.

Following are the different parameter which are necessary for the model set-up:

- i. Physics
- ii. Geometry
- iii. Meshing
- iv. Initial and boundary conditions
- v. Different simulations options

2.7.1 Basic Concept

Flow-3D is a transient solution and finite difference CFD model which solves the non-uniform grid of the Reynolds average Navier stroke equation. The volume-of-

fluid (VOF), which is a free surface algorithm, tracks the free surface movement by measuring the fluid fraction (in this case, water) in each computational cell. The fluid filled into the cells is transported through the advection diffusion equation in a conservative form. VOF method allows the fluid to form or destroy bubbles, enables transient shocks and jets simulations and to collide the fluid with solid bodies.

2.7.2 Governing Equations

The governing equations for the model are:

a) MASS CONTINUITY EQUATION

The mass continuity equation is:

$$V_F \frac{\partial \rho}{\partial t} + \frac{\partial}{\partial x}(\rho u A_x) + R \frac{\partial}{\partial y}(\rho v A_y) + \frac{\partial}{\partial z}(\rho w A_z) + \xi \frac{\rho u A_x}{x} = R_{DIF} + R_{SOR} \quad (2.1)$$

Where, V_F = fractional volume open to flow, P = Fluid Density, R_{DIF} = Turbulent Diffusing Term, R_{SOR} = Mass Source, A_x = Fractional area in x-direction, A_y = Fractional area in y-direction, A_z = Fractional area in z-direction.

R_{DIF} equation is as follow:

$$R_{DIF} = \frac{\partial}{\partial x} \left(v_\rho A_x \frac{\partial \rho}{\partial x} \right) + R \frac{\partial}{\partial y} \left(v_\rho A_y R \frac{\partial \rho}{\partial y} \right) + \frac{\partial}{\partial z} \left(v_\rho A_z \frac{\partial \rho}{\partial z} \right) + \xi \frac{v_\rho A_x}{x} \frac{\partial \rho}{\partial x} \quad (2.2)$$

b) MOMENTUM EQUATION

The momentum equations used in model are as follow:

$$\begin{aligned}
\frac{\partial u}{\partial t} + \frac{1}{V_F} \left\{ uA_x \frac{\partial u}{\partial x} + vA_y R \frac{\partial u}{\partial y} + wA_z \frac{\partial u}{\partial z} \right\} - \xi \frac{A_y v^2}{xV_F} &= -\frac{1}{\rho} \frac{\partial p}{\partial x} + G_x + f_x - b_x - \frac{R_{SOR}}{\rho V_F} (u - u_w - \delta u_s) \\
\frac{\partial v}{\partial t} + \frac{1}{V_F} \left\{ uA_x \frac{\partial v}{\partial x} + vA_y R \frac{\partial v}{\partial y} + wA_z \frac{\partial v}{\partial z} \right\} + \xi \frac{A_y w v}{xV_F} &= -\frac{1}{\rho} \left(R \frac{\partial p}{\partial y} \right) + G_y + f_y - b_y - \frac{R_{SOR}}{\rho V_F} (v - v_w - \delta v_s) \\
\frac{\partial w}{\partial t} + \frac{1}{V_F} \left\{ uA_x \frac{\partial w}{\partial x} + vA_y R \frac{\partial w}{\partial y} + wA_z \frac{\partial w}{\partial z} \right\} &= -\frac{1}{\rho} \frac{\partial p}{\partial z} + G_z + f_z - b_z - \frac{R_{SOR}}{\rho V_F} (w - w_w - \delta w_s)
\end{aligned} \tag{2.3}$$

2.7.3 Turbulent Models in Flow 3D

The turbulent kinetic equation is (Flow-3D manual):

$$k_T = \frac{1}{2} \left(\overline{u'^2} + \overline{v'^2} + \overline{w'^2} \right) \tag{2.4}$$

Where u, v, w shows x, y, and z components of fluid velocity having turbulent fluctuations.

The transport equation is as follow:

$$\frac{\partial k_T}{\partial t} + \frac{1}{V_F} \left\{ uA_x \frac{\partial k_T}{\partial x} + vA_y \frac{\partial k_T}{\partial y} + wA_z \frac{\partial k_T}{\partial z} \right\} = P_T + G_T + \text{Diff}_{k_T} - \varepsilon_T \tag{2.5}$$

Where k_T is the turbulent kinetic energy, A_x , A_y , A_z and V_F are FLOW-3D's FAVOR™ functions, P_T is turbulent kinetic energy:

$$P_T = \text{CSPRO} \left(\frac{\mu}{\rho V_F} \right) \left\{ \begin{aligned} &2A_x \left(\frac{\partial u}{\partial x} \right)^2 + 2A_y \left(R \frac{\partial v}{\partial y} + \xi \frac{u}{x} \right)^2 + 2A_z \left(\frac{\partial w}{\partial z} \right)^2 \\ &+ \left(\frac{\partial v}{\partial x} + R \frac{\partial u}{\partial y} - \xi \frac{v}{x} \right) \left[A_x \frac{\partial v}{\partial x} + A_y \left(R \frac{\partial u}{\partial y} - \xi \frac{v}{x} \right) \right] \\ &+ \left(\frac{\partial u}{\partial z} + \frac{\partial w}{\partial x} \right) \left(A_z \frac{\partial u}{\partial z} + A_x \frac{\partial w}{\partial x} \right) \\ &+ \left(\frac{\partial v}{\partial z} + R \frac{\partial w}{\partial y} \right) \left(A_z \frac{\partial v}{\partial z} + A_y R \frac{\partial w}{\partial y} \right) \end{aligned} \right\} \tag{2.6}$$

Where CSPRO is a turbulence parameter and is related (if used) to the cylindrical coordinate system. The buoyancy term is

$$G_T = -CRHO \left(\frac{\mu}{\rho^3} \right) \left(\frac{\partial \rho}{\partial x} \frac{\partial p}{\partial x} + R^2 \frac{\partial \rho}{\partial y} \frac{\partial p}{\partial y} + \frac{\partial \rho}{\partial z} \frac{\partial p}{\partial z} \right) \quad (2.7)$$

Where CRHO is another turbulence parameter.

The diffusion term is

$$Diff_{k_T} = \frac{1}{V_F} \left\{ \frac{\partial}{\partial x} \left(v_k A_x \frac{\partial k_T}{\partial x} \right) + R \frac{\partial}{\partial y} \left(v_k A_y R \frac{\partial k_T}{\partial y} \right) + \frac{\partial}{\partial z} \left(v_k A_z \frac{\partial k_T}{\partial z} \right) + \xi \frac{v_k A_x k_T}{x} \right\} \quad (2.8)$$

Where v_k is the diffusion coefficient; it is calculated on the basis of the local value of turbulent viscosity.

a) k-ε MODEL

A more enlightened and wider-used model includes two transport equations for the turbulent kinetic energy k_T and its dissipation ε_T , the so-called k-ε model. A supplementary transport equation is to be solved for the turbulent dissipation, ε_T :

$$\frac{\partial \varepsilon_T}{\partial t} + \frac{1}{V_F} \left\{ u A_x \frac{\partial \varepsilon_T}{\partial x} + v A_y R \frac{\partial \varepsilon_T}{\partial y} + w A_z \frac{\partial \varepsilon_T}{\partial z} \right\} = \frac{CDIS1 \cdot \varepsilon_T}{k_T} (P_T + CDIS3 \cdot G_T) + Diff_\varepsilon - CDIS2 \frac{\varepsilon_T^2}{k_T} \quad (2.9)$$

Here $CDIS1$, $CDIS2$, and $CDIS3$ are dimensionless user-adjustable parameters, and have default values of 1.44, 1.92 and 0.2, respectively for the k-ε model. The diffusion of dissipation, $Diff_\varepsilon$, is:

$$Diff_\varepsilon = \frac{1}{V_F} \left\{ \frac{\partial}{\partial x} \left(v_\varepsilon A_x \frac{\partial \varepsilon_T}{\partial x} \right) + R \frac{\partial}{\partial y} \left(v_\varepsilon A_y R \frac{\partial \varepsilon_T}{\partial y} \right) + \frac{\partial}{\partial z} \left(v_\varepsilon A_z \frac{\partial \varepsilon_T}{\partial z} \right) + \xi \frac{v_\varepsilon A_x \varepsilon_T}{x} \right\} \quad (2.10)$$

b) RNG MODEL

Renormalization-group (RNG) method is also used to model the turbulence energy. This approach uses statistical methods to calculate the average turbulence equations, such as turbulent kinetic energy and its dissipation rate. The RNG model uses equation similar to the k-ε model equations. Nevertheless, in the RNG model, the equation constants found empirically are derived explicitly. The RNG model is

usually more applicable than the tradition $k\pi$ model. In particular, the RNG model is known to describe turbulence flows and flows with a more accurate low intensity. Interestingly, CDIS1 and CNU's default values are different from those used in the $k-\pi$ model respectively, they are 1.42 and 0.085.

2.8 PAST STUDIES ON FLOW-3D

Sehrosh, M. (2015) estimated discharge co-efficient of Neelum-Jhelum spillway and performance of stilling basin at 100 years return period. From the results he concluded that the difference of results for discharge co-efficient in physical modelling and numerical modelling are 5.3 % as shown in Figure 2.10. After running CFD model for different energy dissipaters, stilling basin was chosen to be the best option for Neelum-Jhelum project.

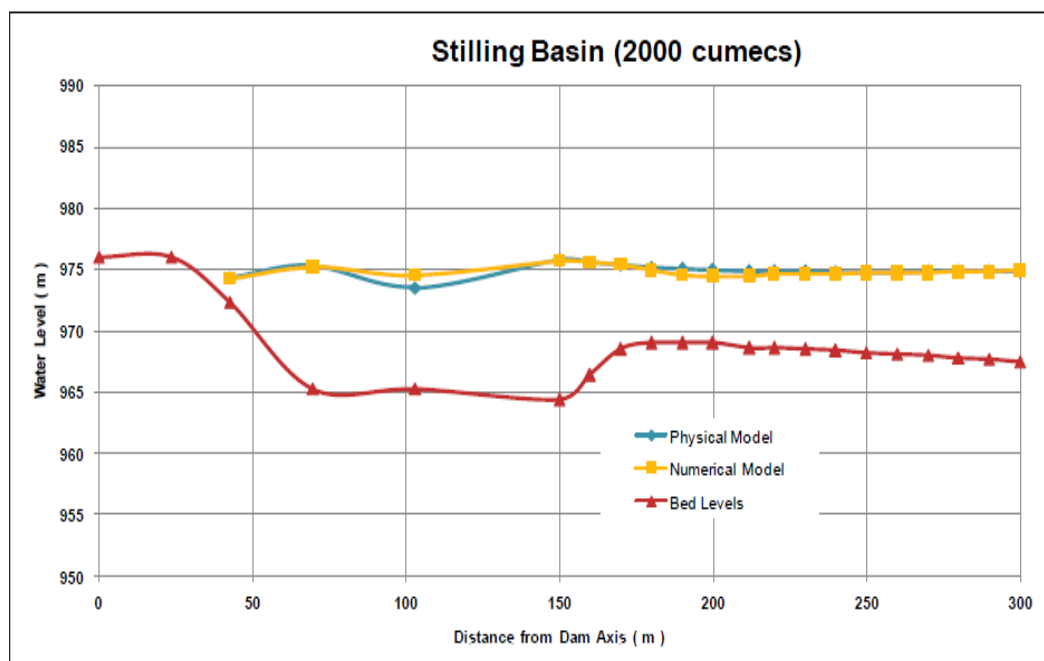

Figure 2.10 Stilling basin performance (2000 Cumecs)

Abbas Parsaic et. al. (2015) used CFD model to analyze the flow pattern at guide wall of Kmal-Saleh Dam as shown in Figure 2.11. From his study he showed

that the geometry of guide wall caused instability for flow pattern. The performance of weir was reduced for removal of peak discharges using existing shape of guide wall. For this purpose, he considered the proposed design discharge for return period of 5, 100 and 1000 years and concluded that by increasing the flow rate, spillway secondary flow and vortex were removed.

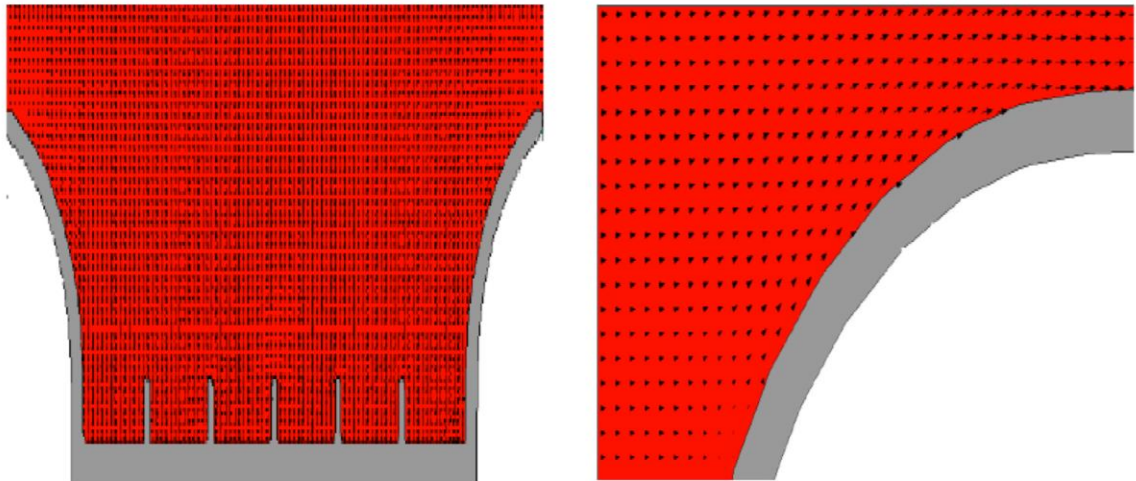

Figure 2.11 Geometry of guide wall

Ebrahim Nohani, (2015) investigated the morning glory spillway using the USACE and USBR standards. He compared results of laboratory research and these standards. From that comparison he concluded that numerical tools have some limitations especially when using for actual models. From Figure 2.12 it can be seen that at different values of head on the crest, variation of 5-8 % was studied.

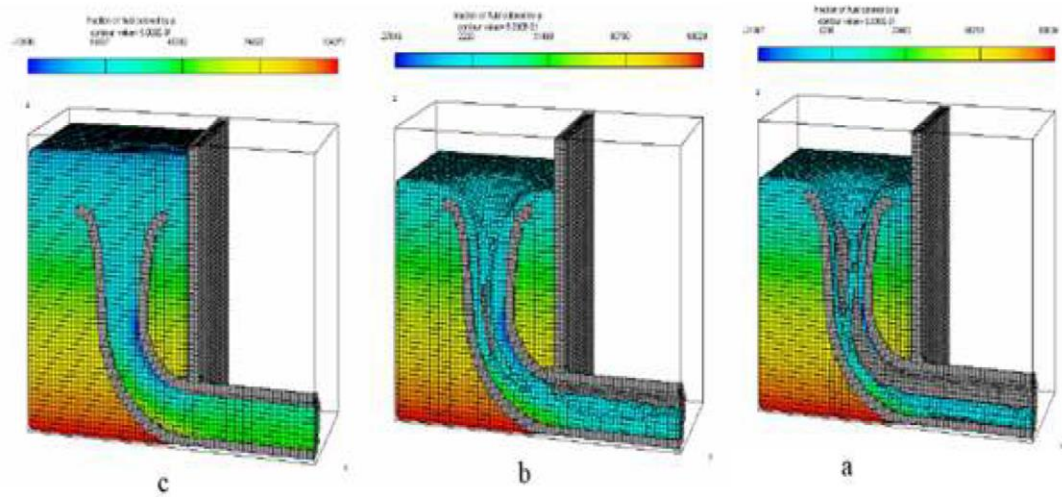

Figure 2.12 Head values

E-Fadaei-Kermani (2014) studied flow over chute spillway using CFD model. In his study he compared the computed results and the model results of piezometric pressure and flow velocity at four different flow rates. Figure 2.12 concludes that the difference between the values of velocities were 5.47 % and that of piezometric pressures were 7.97 %.

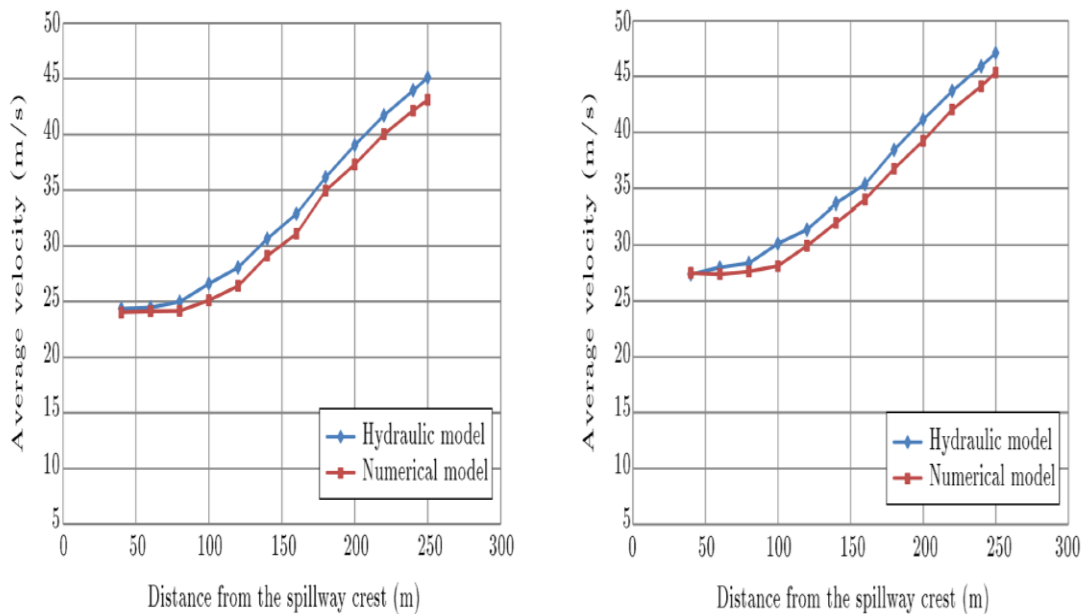

Figure 2.13 Velocity vs. Distance

Mohsen Maghrebi et. al. (2012) studied the evaluation of flow over broad crested weir and its stilling basin. He made two modifications in hydraulic jump and hydraulic energy damping to ensure their quality using Flow 3-D (CFD) model. From his study he expressed that end sill can decrease length of hydraulic jump by increasing its height in stilling basin as shown in Figure 2.14.

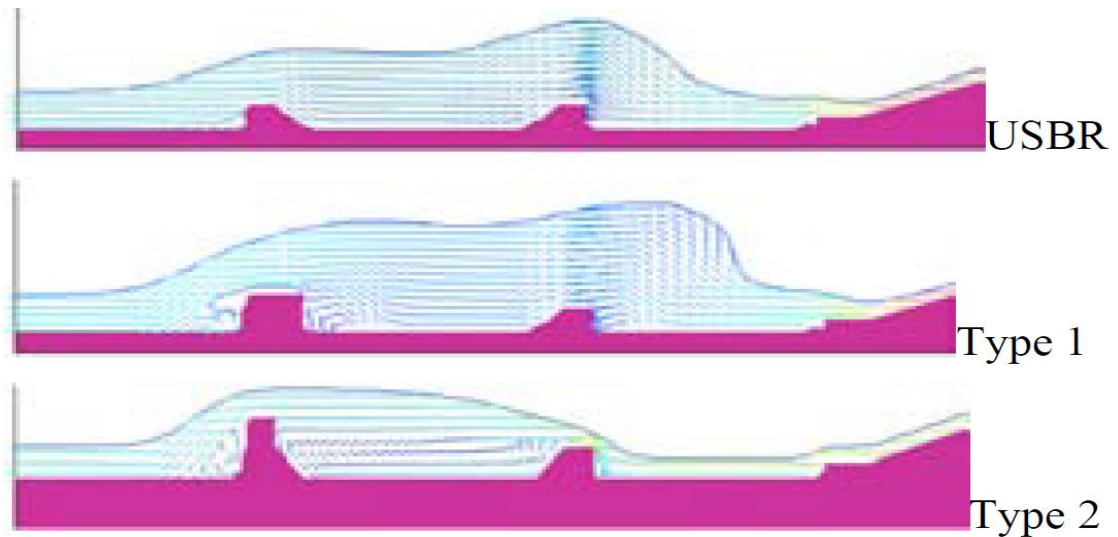

Figure 2.14 Different USBR types

Zhenwei et. al. (2012) simulated the flow characteristics over the whole spillway using CFD model under considerations of flood level and design flood level. He showed that results from modeling and experiments are well related for surface elevation, flow velocity and pressures. From Figures 2.15 and 2.16 it is cleared that flow pattern of original design is complex for two-hole scheme using boundary conditions, so he modified it to one-hole scheme by reducing the width from 14 m to 10 m. From results he concluded that one whole scheme is better than two-hole scheme.

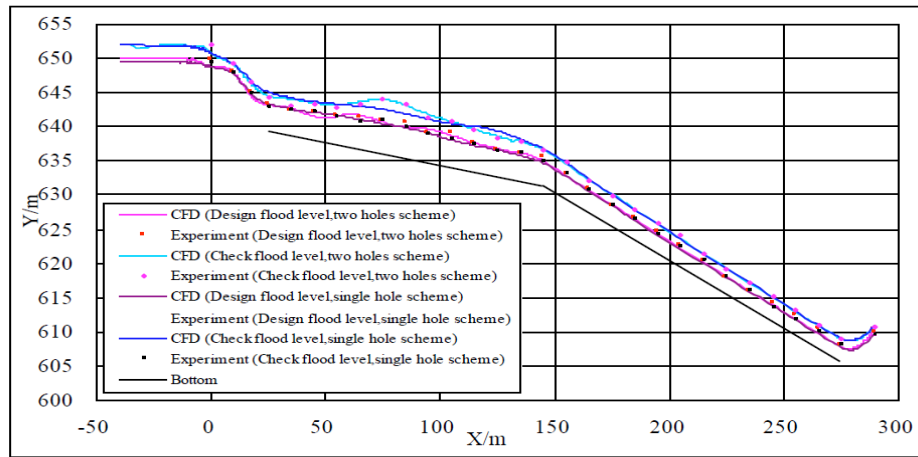

Figure 2.15 Flow patterns

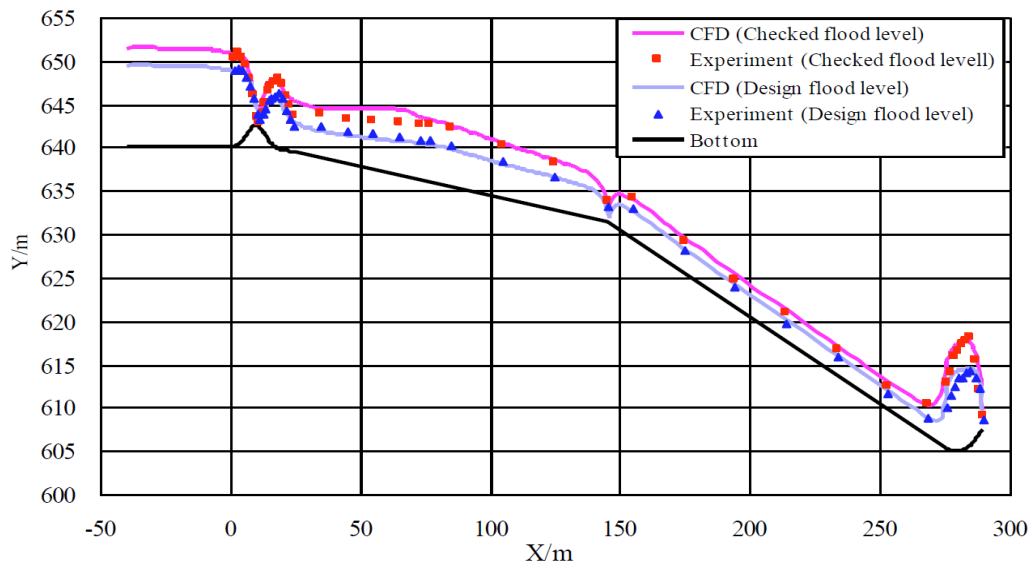

Figure 2.16 Flow patterns at flood levels

Sung-Duk-Kim et. al. (2010) applied CFD model on Keria Dam in Indonesia to analyze its flow characteristics. In his study he showed that during high flood level the approach channel is overflowed due to its faulty design discharge. He concluded that the height of approach channel should be located up to the crest of the dam. The flow in the spillway was stable after comparison of results and physical modelling.

Paul G. Chanel et. al. (2008) used Flow 3-D (CFD) model to analyze flow over ogee spillway. For this purpose, he took three case studies and modelled their p/H_d ratio. From results he concluded that for smallest gate opening there was some error in two cases. He also concluded that when spillway height to design head ratio is reduced considerably as summarized in Figure 2.17, the results showed that discharge increases in CFD model as compared to physical model values/results.

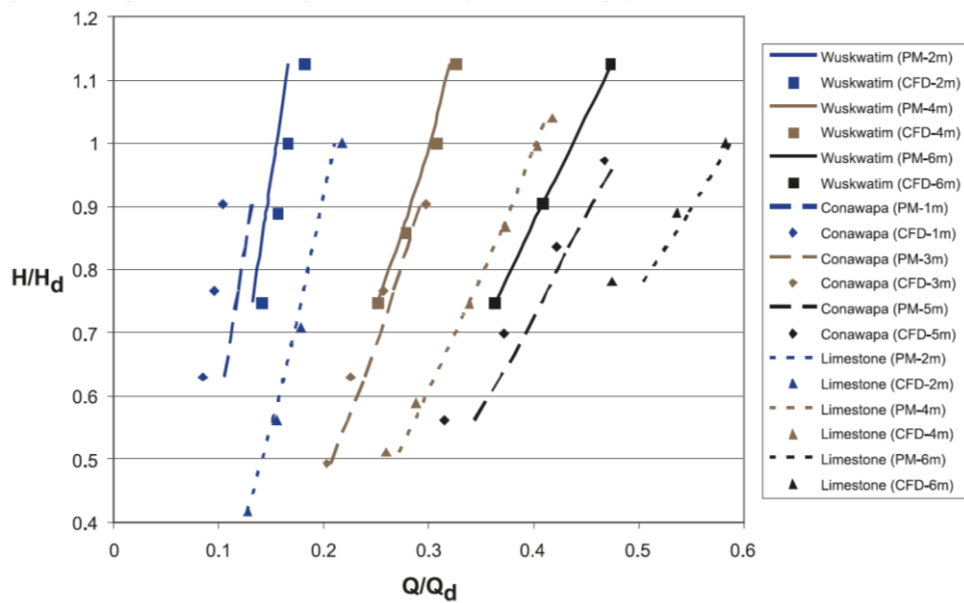

Figure 2.17 Physical model values

Doering et. al. (2007) compared the physical results for pressures, water surface elevations and rating curves to that of the CFD model results. He showed that results of both physical and numerical modeling were satisfactory, but the discharges were in difference with dependence of p/H_d ratio. From his study he concluded that results of surface profile and pressures by CFD model were very close to that of physical results. Results are summarized in Table 2.2.

Table 2.2 Average physical model difference

Spillway	P/H _d	Average % Difference
Conawapa	1.8	- 5.2
Limestone	1.4	2.3
Wuskwatim	0.9	5.0

Dae Geun Kim et. al. (2005) studied the crest pressures, flow rates and water surface over ogee spillway and vertical distribution for pressure and velocity with addition of surface roughness and model scale were investigated using CFD model. From his study he concluded that errors for scale effect were in acceptable range but for surface roughness the errors for flow rate, water surface and crest pressures were insignificant. He also showed that velocity for physical and numerical modelling were different above and below H_m. From results it is seen that pressure on spillway crest was different but vertical pressure distribution was almost same for model scale and surface roughness.

Reda M. et al., (2011) has used this model to model the flow over sharp crested weir. The main objectives were to calculate flow patterns over the weir and to determine the discharge coefficient. In a reasonable accuracy, Flow 3D was able to predict the flow profiles. The discharge coefficient was found to be 0.64, which in the literature was quite similar to that.

2.9 SUMMARY

This chapter has briefly discussed the use of CFD model as a help in the patterns of fluid flows. The theories involved in the modeling of fluids were also mentioned here. Physical modeling in conjunction with cfd modelling is now becoming a standard now a day to save additional cost and time in performance decision making of hydraulic structures. The successful simulation of flow characteristics requires a thorough understanding of mesh sizes and boundary conditions.

Chapter III METHODOLOGY

3.1 INTRODUCTION

This chapter covers the methodology to achieve the objectives set for the M.sc research. Following is the flow chart of methodology:

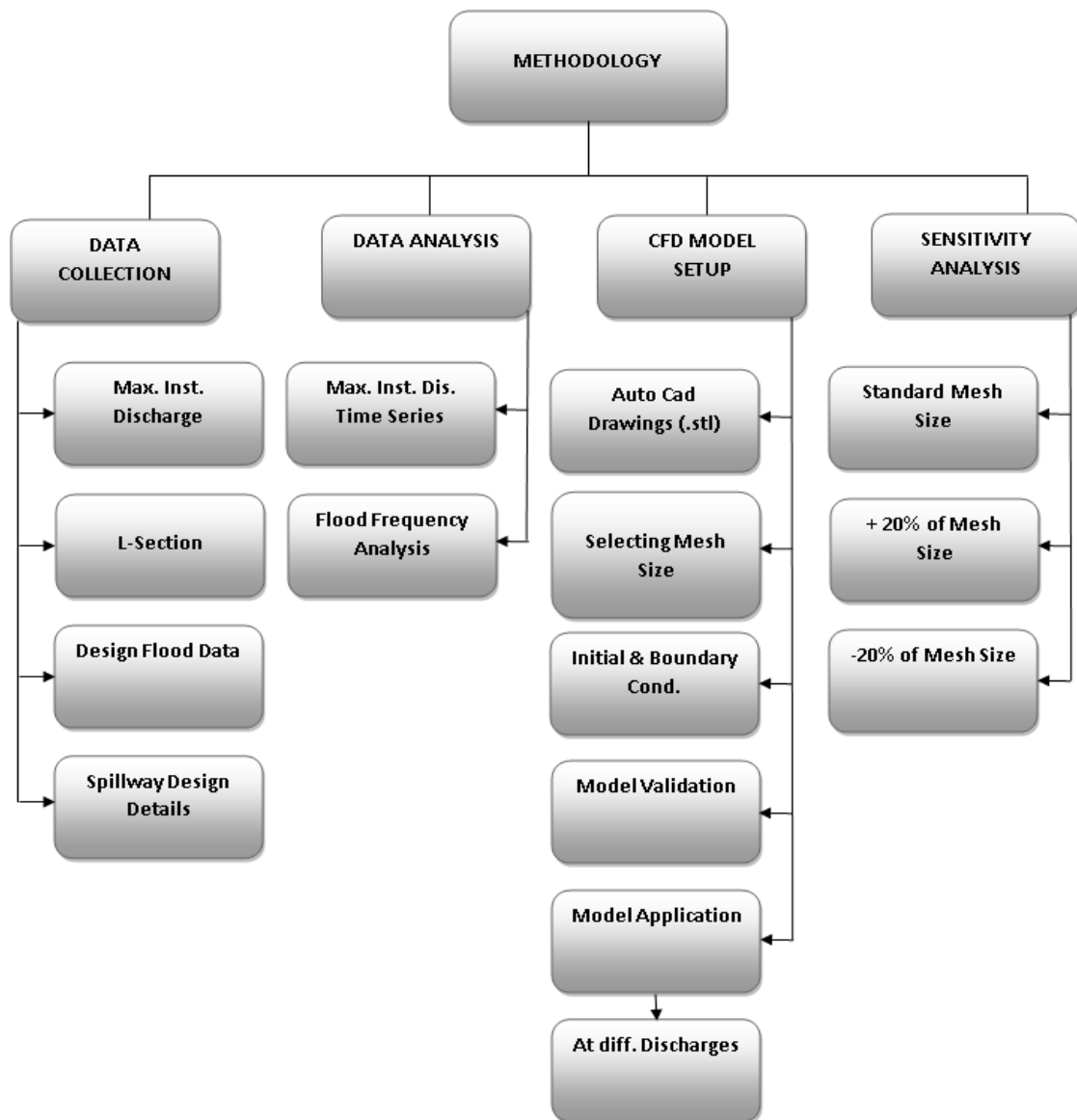

Figure 3.1 Flow chart of the methodology

This methodology includes four major steps. First step is data collection which covers collection of design flood data, detailed engineering drawings of spillway and maximum instantaneous discharge. 2nd step includes data analysis which includes the processing of hard form data into soft form. 3rd step is state of the art approach. This step includes the set-up of the cfd model. Firstly, the AutoCAD files are imported into model using .stl file and then the boundary conditions are assigned to model with specified mesh sizes. Flow-3D is simulated for flow characteristics for different discharges at different sections of spillway. Model is also well validated for flow depth. 4th step includes the sensitivity analysis of the model for different mesh sizes.

3.2 DATA COLLECTION

The data has been collected from the consultants as well as from the SDO (small dam organization). Following data has been collected:

3.2.1 Maximum Instantaneous Discharge

Maximum instantaneous discharge was collected from the Feasibility report (2015) which was then utilized for the validation of the Flow-3D model. The result of the calibrated maximum discharge was compared to that of the maximum instantaneous discharge collected.

3.2.2 Longitudinal Section

The engineering design details are collected from the consultants which includes detail plan and L-section of the spillway according to which the geometry of the spillway was created using AUTOCAD. These designs are shown in the figures below:

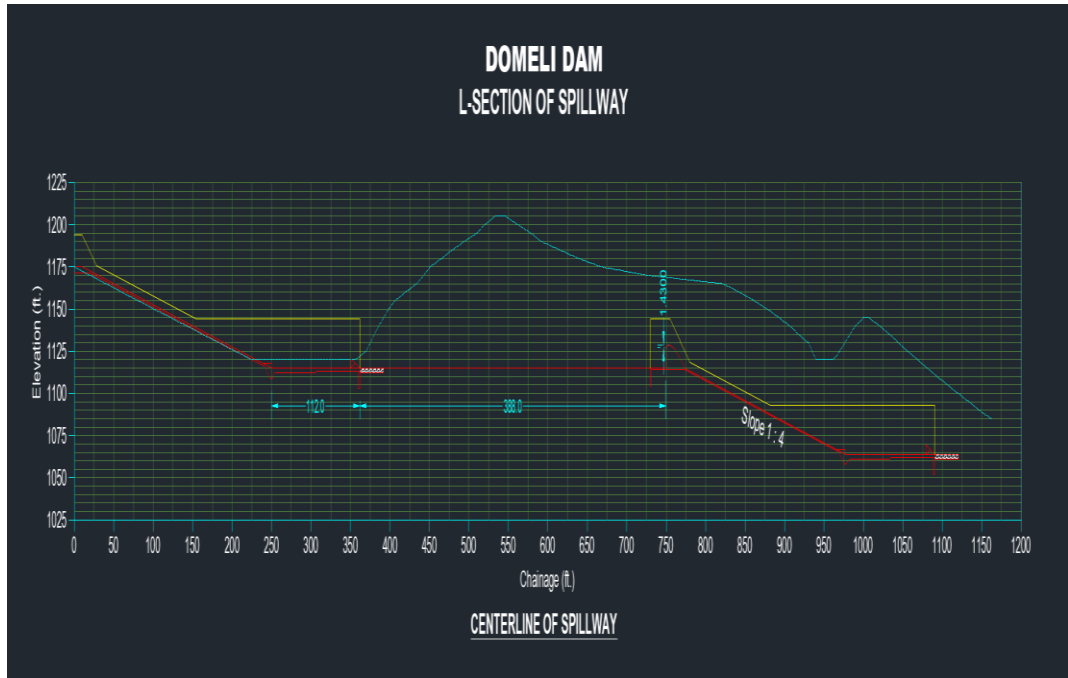

Figure 3.2 L-section of Domeli Dam spillway

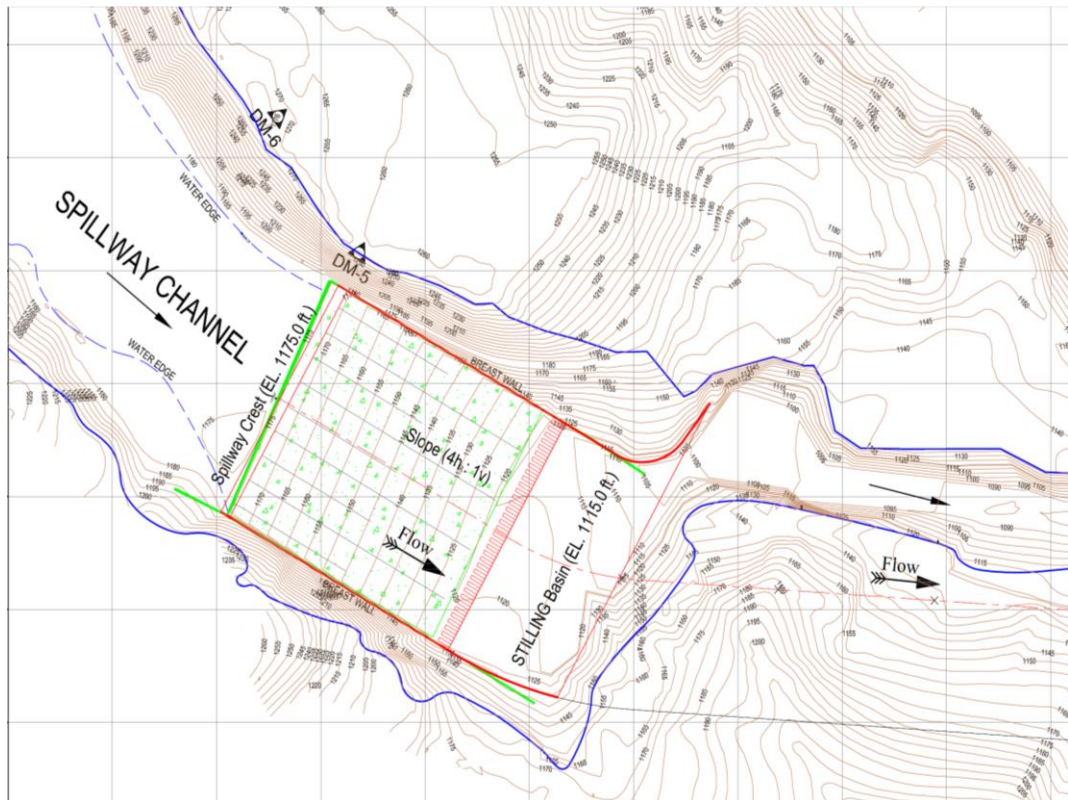

Figure 3.3 Domeli Dam Spillway layout plan

3.2.3 Spillway Design Details

Design details for the spillway were collected to design the spillway according to the actual condition so the model runs accurately. For this purpose, different design details were collected from the SDO (Small dams Organization) which are shown in the Table 3.1:

Table 3.1 Design details of Domeli spillway

Sr. #	Feature	Description
1	Area of catchment	170 Km ²
2	Maximum height	36.6 m
3	HFL	362 m
4	Type of spillway	Chute spillway (USBR type II)
5	Capacity of Spillway	1185 Cumecs

3.3 DATA ANALYSIS

The data was collected in the hard form which was then digitally converted for using the numerical model. The results of the data are plotted in the AutoCAD for further use in the numerical model. The maximum instantaneous discharge time series and flood frequency analysis was done for the data analysis.

3.3.1 Rainfall Frequency Analysis

The rainfall frequency analysis was done using the gumbel method for the last 33 years data of the Jehlum station.

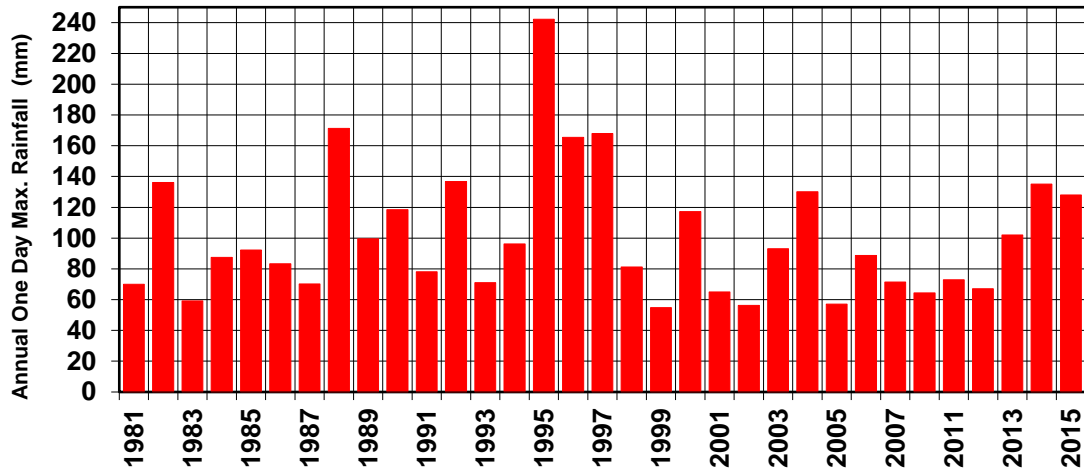

Figure 3.4 Time series of one day maximum rainfall

- i. Rainfall frequency analysis was carried out using the annual one-day maximum rainfall data of Jehlum metrological station for last 33 years (Punjab Irrigation Department).
- ii. Highest and lowest values of annual one day maximum rainfalls were observed in 1995 & 1999 with values of 242.2 mm and 54.9 mm respectively.
- iii. Rainfalls corresponding to 2, 5, 10, 20, 25, 50, 100, 500 & 1000 years return period were computed using Gumbel method.

3.3.2 Flood Estimation Using HEC-HMS

- i. Floods computed for various return period corresponding to 2, 5, 10, 50, 100, 500 & 1000 years.
- ii. Flood estimation is done using SCS unit hydrograph method.
- iii. Discharge values computed from these are further used for the evaluation of flow characteristics in FLOW-3D

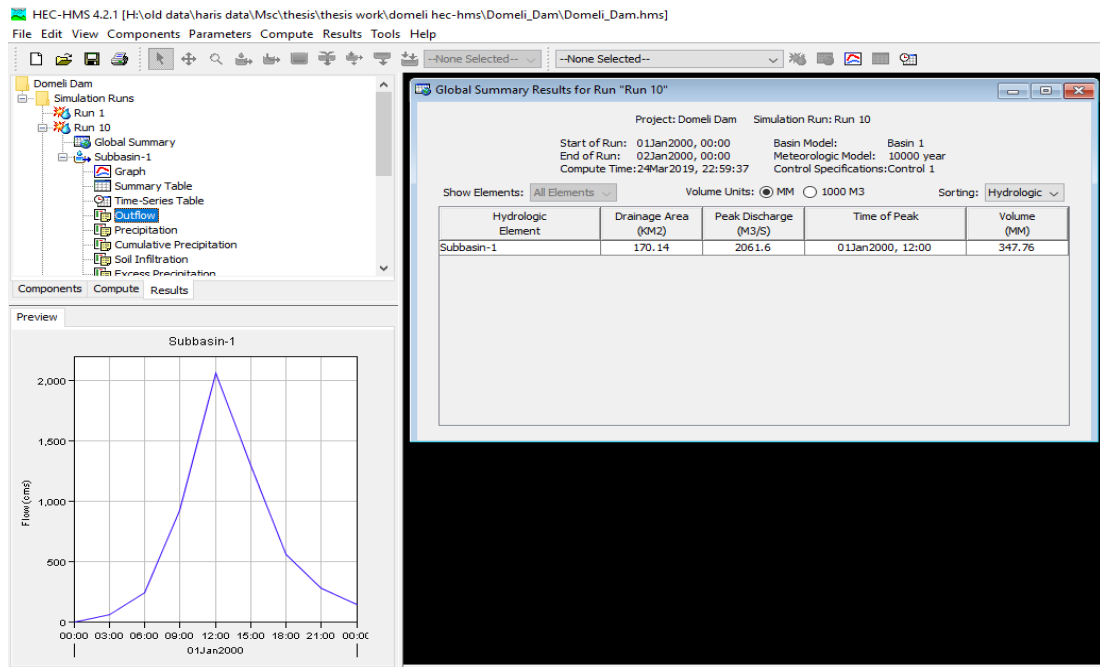

Figure 3.5 Flood estimation using HEC-HMS

3.4 CFD MODEL SETUP

The first step in Flow-3D modelling is to create a 3-dimensional geometry files for the model. For this purpose, all the 2-dimensional drawings are first converted into 3-dimensional drawings. Then these 3-dimensional drawings are converted into .stl (stereolithography) format. After importing this .stl file into the model the mesh geometry is created and after that all the necessary boundary conditions were given to the model to simulate the drawings and obtain the desired results in graphical as well as in the video format.

3.4.1 Modelling Assumptions

- i. In this research, scouring has not been modelled.
- ii. Mesh size is taken as 1m x 1m. Due to coarser grid size, it is difficult to obtain accurate mean velocity through the cross section.

- iii. The simulation time is taken to be 250 sec.
- iv. Sediment transportation is not considered.
- v. Economic analysis has not been carried out.

3.4.2 Setting up of Flow-3D Model

The steps used are as follow:

3.4.2.1 Geometric data

For this, the drawings are converted to .stl formats with the use of AUTOCAD software. Steps related to this are:

- i. Firstly 2-dimentional drawings were converted into 2-dimentional closed objects.
- ii. Secondly, 2-dimentional closed object are extruded into 3-dimentional solid object.
- iii. 3-dimentional objects are then converted into .stl file format.
- iv. .stl is then opened in Flow-3D model as geometry file which are solid objects by default.

The 3-dimentional solid objects created for the model are as follow:

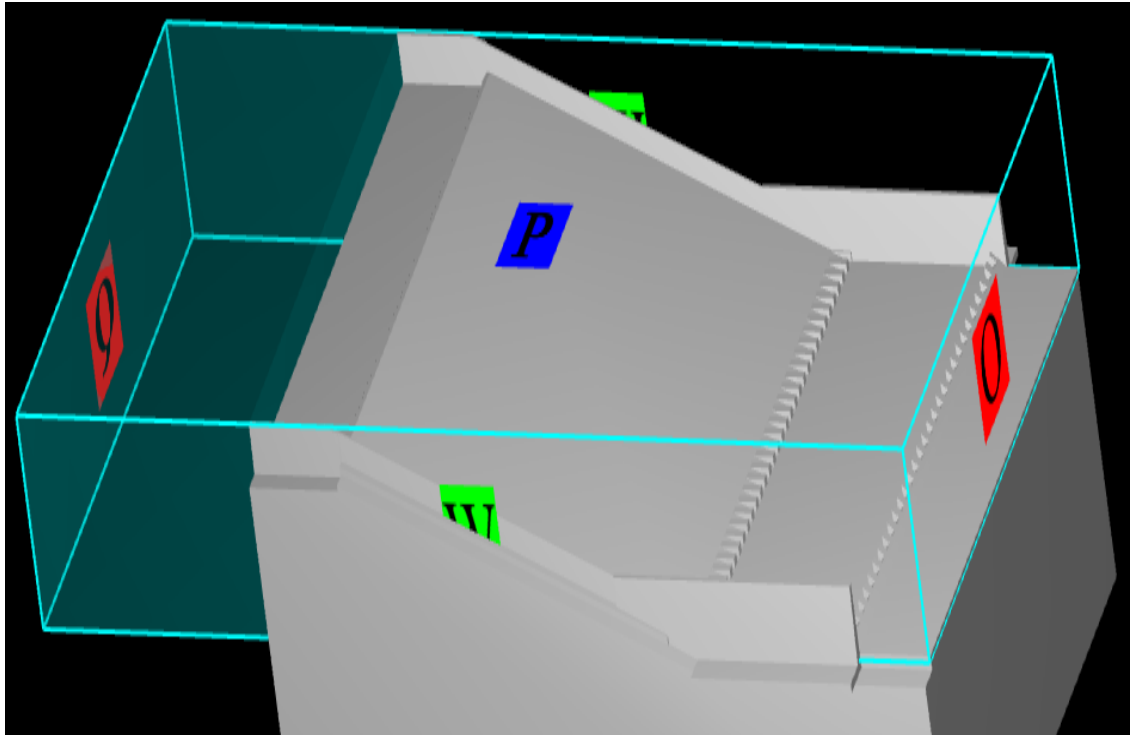

Figure 3.6 Geometry of Domeli Dam Spillway

3.4.3 Numerical Model Setup

The numerical modelling is carried out by following steps

3.4.3.1 Simulation manager

In simulation manager window, the “Workspace” and the “Simulation” has been created.

3.4.3.2 Model Setup

This bar includes following sub-bars:

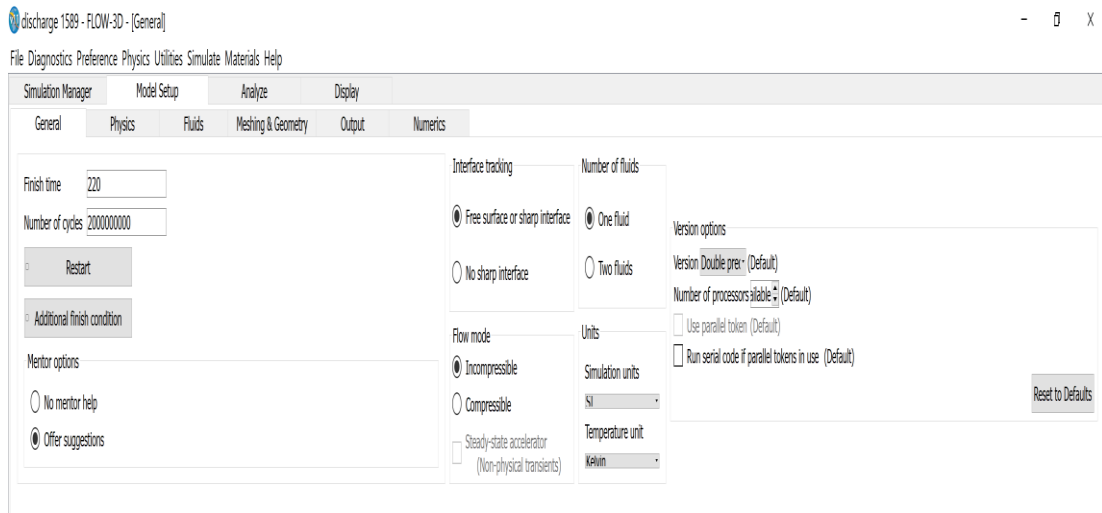

Figure 3.7 Model setup of Flow-3D

3.4.3.2.1 General

In this step the “finish time” is first given. Units of the models are selected to be “SI”, whereas temperature units are set to be “Kelvin”.

3.4.3.2.2 Physics

The “gravity and non-inertial reference frame” options is selected. Also, the viscosity and turbulence option is selected in which further RNG model is selected under viscous flow option.

3.4.3.2.3 Fluids

Many of the fluids are provided in this model, out of which “Water at 20⁰c” has been selected. Also, the compressibility for the fluid is provided to be 0.

3.4.3.2.4 Meshing & Geometry

This step basically includes the important most steps for Flow-3D model. Firstly the .stl file is imported in the model in geometry model settings. After importing the file, the mesh is created around the geometry file. Meshing can be done either by manual or by Auto mesh option for time saving. Mesh boundary can also be adjusted accordingly using the adjust option.

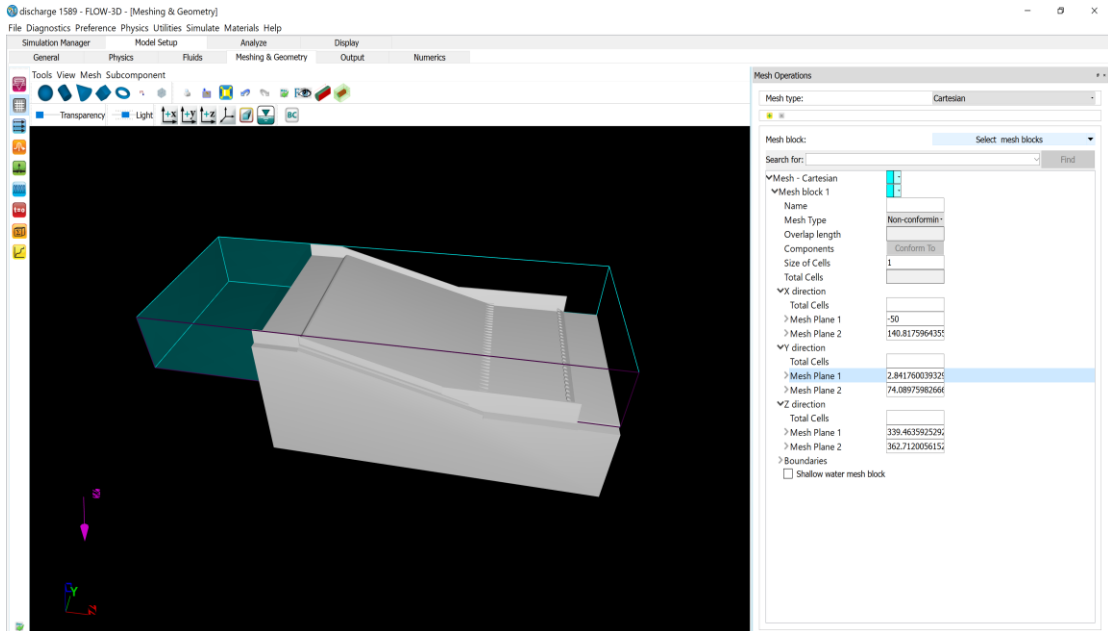

Figure 3.8 Mesh geometry in Flow-3D

3.4.3.2.5 Boundary conditions

Boundary conditions are chosen for the X_{min} , X_{max} , Y_{min} , Y_{max} , Z_{min} & Z_{max} . The conditions at the boundary include symmetry, wall, defined pressure, volume flow rate etc.

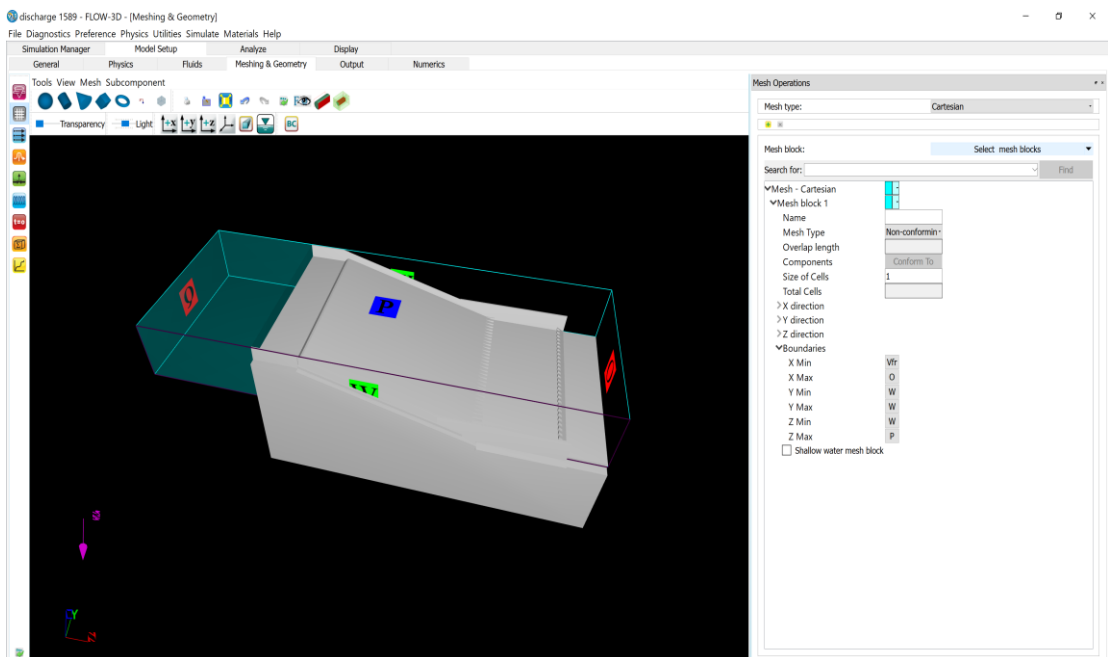

Figure 3.9 Boundary condition in Flow-3D

3.4.3.2.6 Output

The selected data options to be shown as output are included in this tab. This also includes hydraulic data such as depth of fluid, height of fluid and amount of Fluid, etc. The plot data time interval has also been provided in this window.

3.4.3.2.7 Numerics

Here you can choose the preference of implicit solver. You can pick the fluid flow solver option here, i.e. Equation of momentum & stability, field of constant speed & field of zero speed etc

3.4.4 Model Application

The model has been applied for the following discharges:

Table 3.2 Discharge Values

Return Period (years)	Flood Magnitudes (Cumecs)
2	268.5
5	486.8
10	634.9
50	974.7
100	1116
500	1448
1000	1589

The results have been shown in the next chapter in tabular as well as graphical format. The results includes the simulation of flow characteristics for these discharges at different cross-sections of the spillway, sensitivity analysis scenarios. The results also show the energy dissipation system with respect to these discharges at the start and at

the end of the stilling basin. Turbulent energies also given against the maximum discharge reported for 1000-year return period.

3.5 SENSITIVITY ANALYSIS

Flow-3D is a physically based model so, calibration is not needed (USBR, 2009). But sensitivity analysis is required for correct model applications. In the present study sensitivity analysis of the Flow-3D model was carried out to its mesh size. The mesh size was firstly increased upto 20% (1.2 m) and the mesh size was decreased by 20 % gradually to see the effect of mesh size on the model. Mesh sizes was decreased upto value where there is no change in the model values.

3.5.1 Approach

Sensitivity analysis of Flow-3D model was carried out for following mesh sizes:

- i. Standard mesh size (1m*1m*1m)
- ii. +20% of the mesh size selected (1.2m*1.2m*1.2m)
- iii. -20% of the size selected, until the values are no more changing (0.8m*0.8m*0.8m)

Chapter IV

RESULTS & DISCUSSION

4.1 INTRODUCTION

This chapter discusses the results carried out from rainfall frequency analysis using gumbel method, and then floods are computed using HEC-HMS software. Calibration of HEC-HMS was carried out using the maximum instantaneous discharge for the observed and simulated values. Discharge values calculated from HEC-HMS software are then simulated in the Flow-3D software. Validation of Flow-3D for flow depths. Sensitivity analysis for the model and energy dissipation system was carried out and presented.

4.2 RAINFALL FREQUENCY ANALYSIS

The results of the rainfall frequency analysis are shown in the Table 4.1 and Figure 4.1. Rainfall corresponding to different return periods is shown in the table and figure as well. These return periods are computed using the Gumbel method. The rainfall data of Jhelum station data was used for last 33 years (1983-2015). This data is collected from the PID (Punjab Irrigation Department). From the Table 4.1 it can be seen that the rainfall values are decreasing with the changing return periods and then these return periods are used for the flood estimations. The flood estimation is carried out using the HEC-HMS software.

Table 4.1 Rainfall frequency analysis

Return Period (years) (T)	Rainfall (mm) XT
2	94
5	137
10	165
20	193
25	201
50	228
100	254
500	315
1,000	341

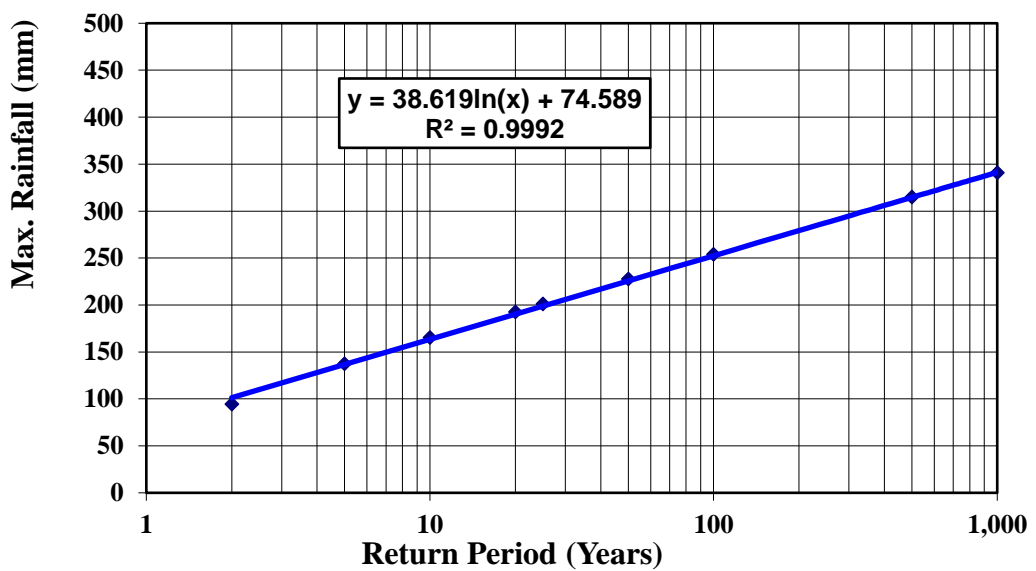

Figure 4.1 Results of Rainfall frequency analysis

4.3 FLOOD FREQUENCY ANALYSIS

Floods were calculated with respect to the calculated rainfalls corresponding to various return periods using HEC-HMS software. Figure 4.2 is showing the different floods values for their corresponding return periods. The maximum values are then taken for each return periods which is then used for the simulation of the spillway flow characteristics.

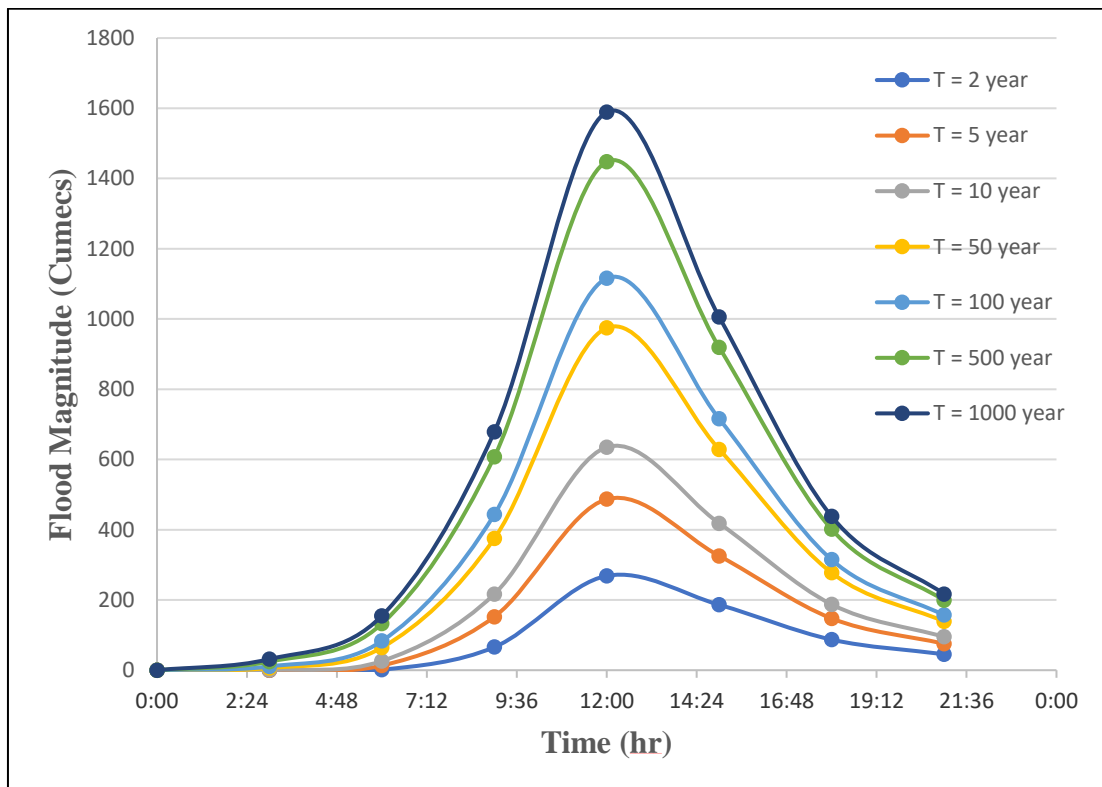

Figure 4.2 Estimation of design flood

The computed flood frequencies for different return periods are used to analyze the stilling basin performance as shown in the Figure 4.9. In the Figure 4.3 the results of highest discharge i.e. 1589 Cumecs are shown. This shows the logarithmic graph of increasing trend line for increasing return periods.

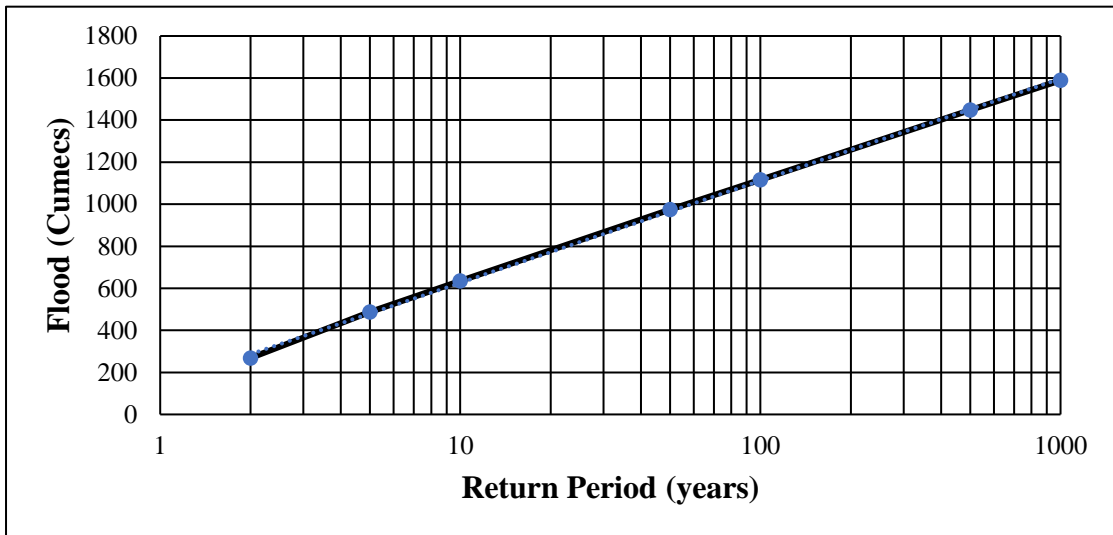

Figure 4.3 Flood frequency analysis

4.4 CALIBRATION OF HEC-HMS

The calibration of HEC-HMS is done by calculating the field discharge using manning equation as follow:

$$\frac{Q}{A} = \frac{1}{n} R^{\frac{2}{3}} S^{\frac{1}{2}} \quad (4.1)$$

Where,

- Q = Discharge
- A = Cross sectional area
- n = Manning's equation,
- R = Hydraulic radius
- S = Bed slope

The parameters are taken from design report of SDO (small dams organization).

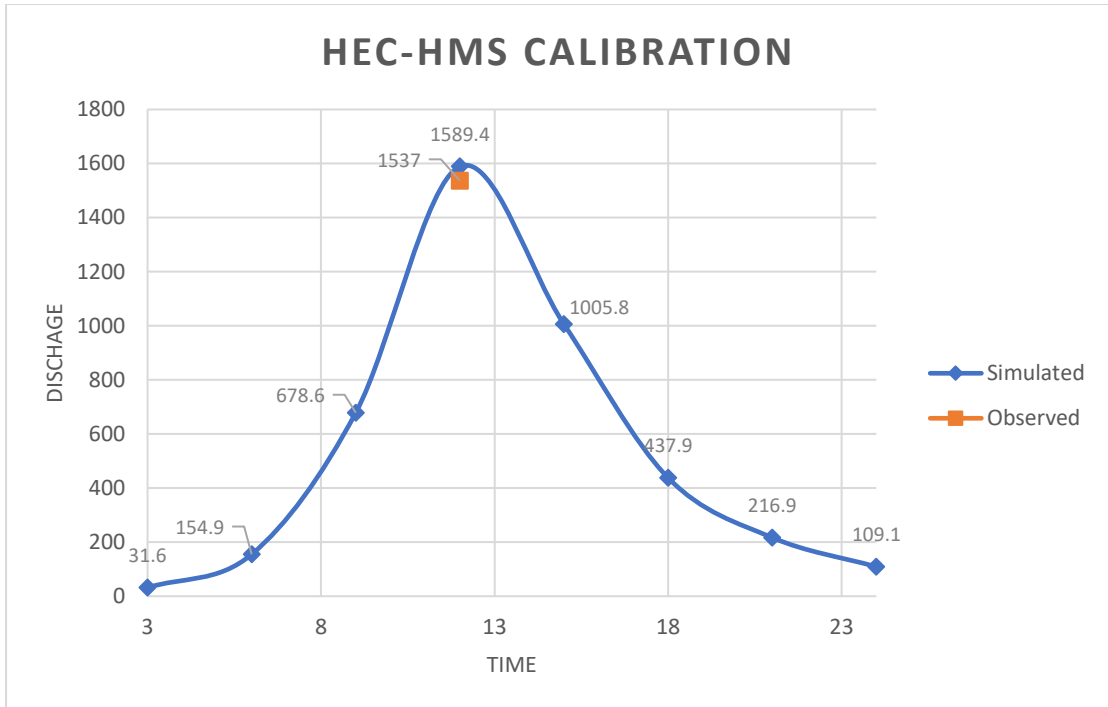

Figure 4.4 Calibration of HEC-HMS

The values of simulated and observed peak discharges are 1589.4 and 1537 respectively. The difference between these values came out to be 3.38%, which shows that the model is well calibrated.

4.5 VALIDATION OF FLOW-3D MODEL

Flow-3D software is validated for the flow depths as shown in Figure 4.5. The observed values of water levels taken from the Domeli dam site and are compared with the computed values from the Flow-3D software. From the figure it can be seen that the difference between the simulated and observed values are closer to each other and has a difference of about 8.5%. These values are taken at the discharge of 1433 Cumecs, at which the spillway of the dam was broken.

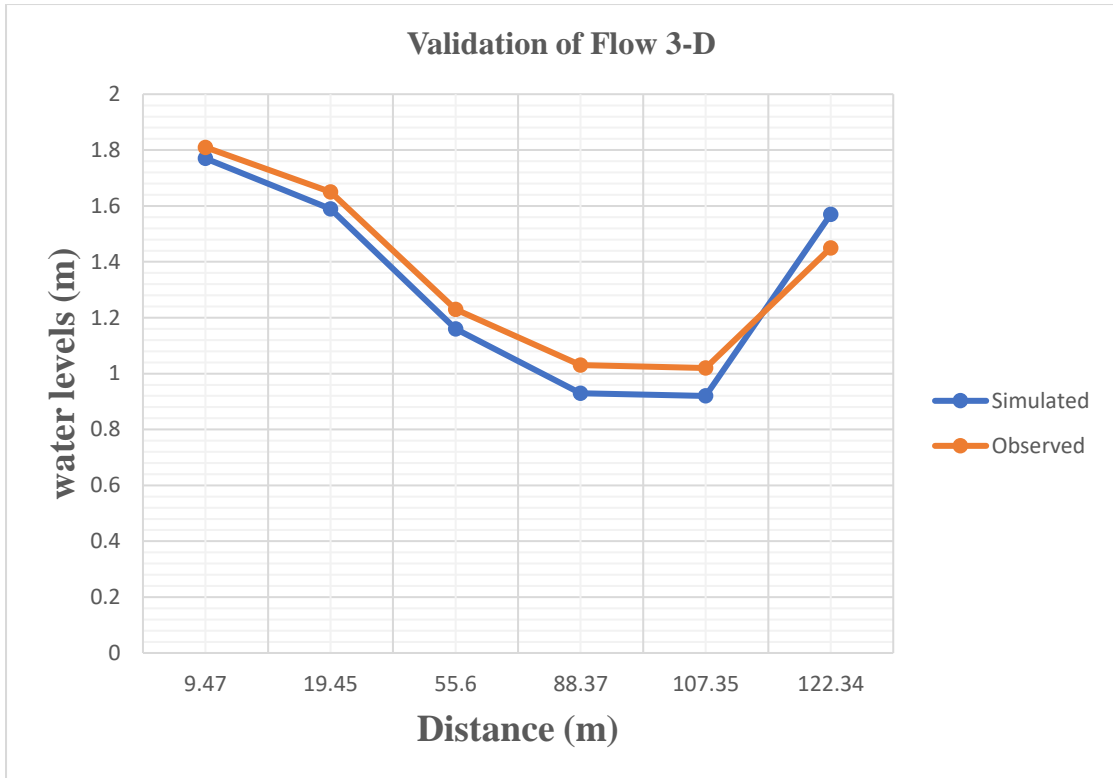

Figure 4.5 Validation of Flow-3D

4.6 SENSITIVITY ANALYSIS

As previously discussed, the sensitivity analysis for Flow-3D model is done by changing the mesh size by increasing it by 20% and decreasing by 20% until the results are not changing. Results were computed for different discharges as shown in the Figure 4.6. Discharges of 1589 Cumecs is shown with blue color, discharge of 1448 Cumecs is shown with orange color and discharge of 1116 Cumecs is shown with grey color. From the figure it can be seen that with the decrease in the mesh size the value of hydraulic head is significantly decreasing. This is due to the reason that when mesh size is decreased then slope is increased as smaller is taken into consideration and hence hydraulic head decreases.

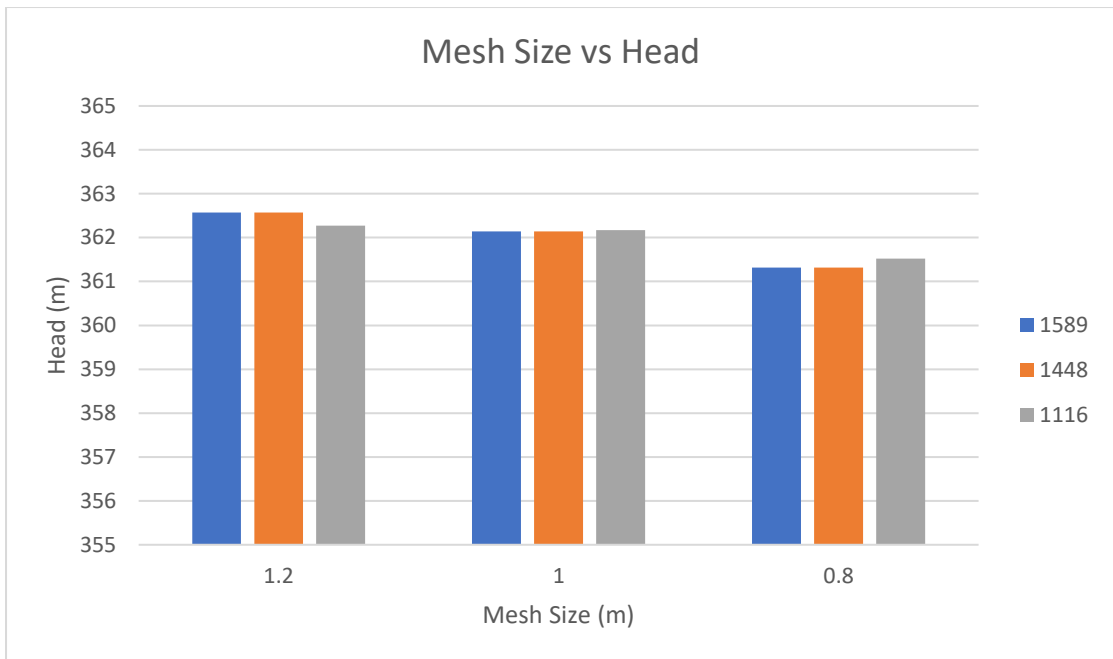

Figure 4.6 Results of Sensitivity analysis

Discharge of 1589 Cumecs is showing significant change in values when we increase the mesh size from 0.6 to 1.2 as shown in Figure 4.7:

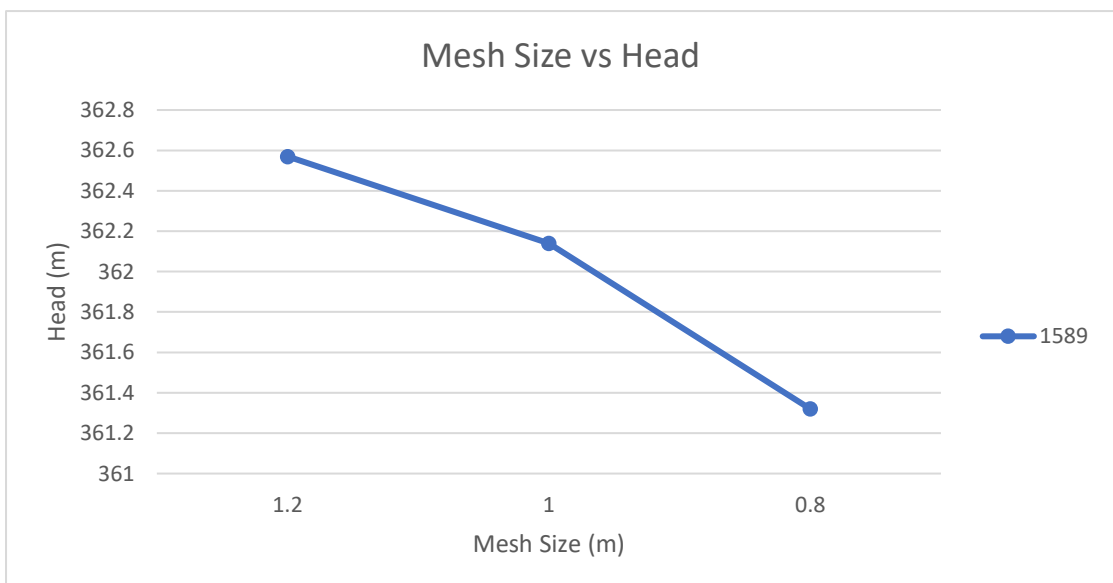

Figure 4.7 Sensitivity analysis at 1589 Cumecs

4.7 Assessment of flow characteristics

Values of different flow parameters like head, velocity and pressure are taken for the assessment/investigation of flow characteristics. The values of these flow parameters were taken at different sections as shown in Figure 4.6 and then calculated using the simulations of Flow-3D for discharges taken from HEC-HMS software, which are shown in Figure 4.2.

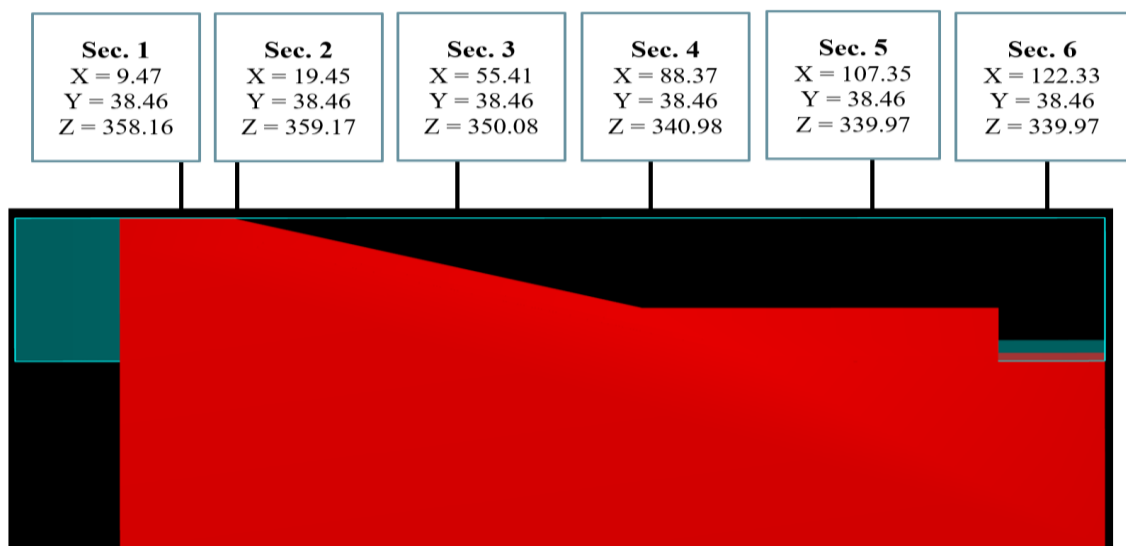

Figure 4.8 Side view of Domeli spillway

4.7.1 Flow Depth

From the crest of the spillway the flow depths are decreasing towards stilling basin which is showing that moving towards the end of the spillway, head decreases. This is because when flow passes from the slope the head of water decreases and its velocity increases. In Figure 4.9 the values of head at different sections are for different discharges are shown.

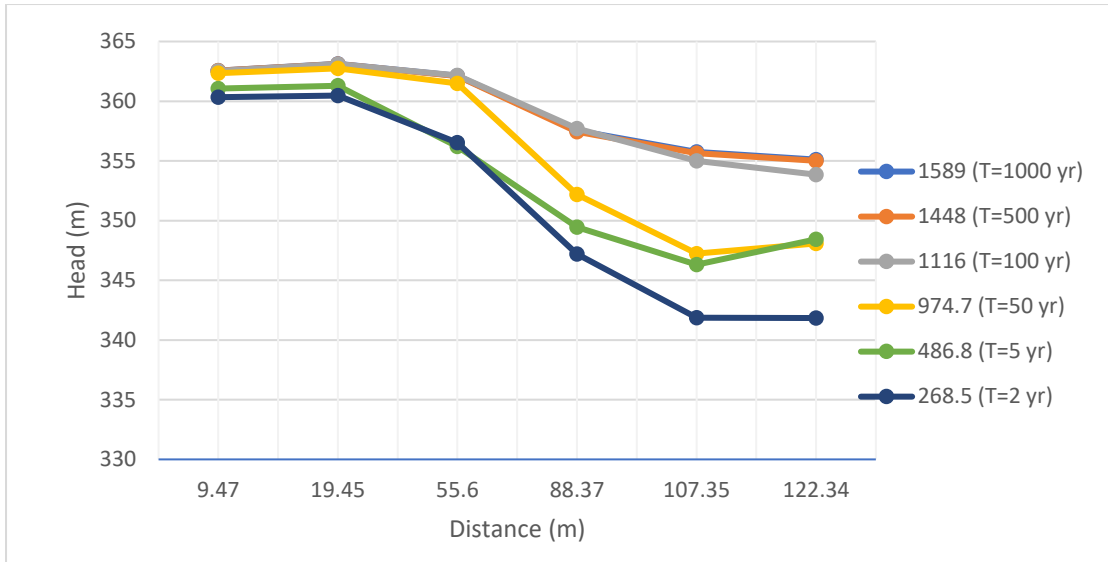

Figure 4.9 Flow depths for different discharges

4.7.2 Velocities

Values of velocities for different discharges at different sections are shown in Figure 4.10. The velocity is increasing up to distance of 88.37 because it is inclined part of spillway and after passing from these the velocity is decreasing as the flow is passing from the stilling basin and the energy of water is broken.

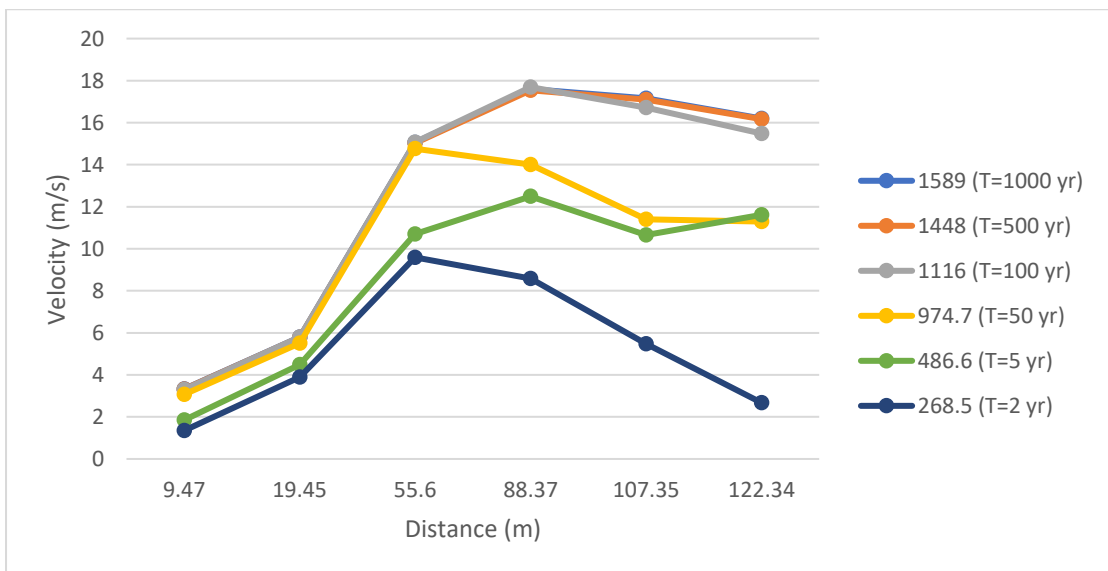

Figure 4.10 Velocities for different discharges

4.7.2.1 Velocity contours

In Figure 4.11, 1558 Cumecs of discharge has been passed through the chute spillway. The velocities are in the range of 20 m/s.

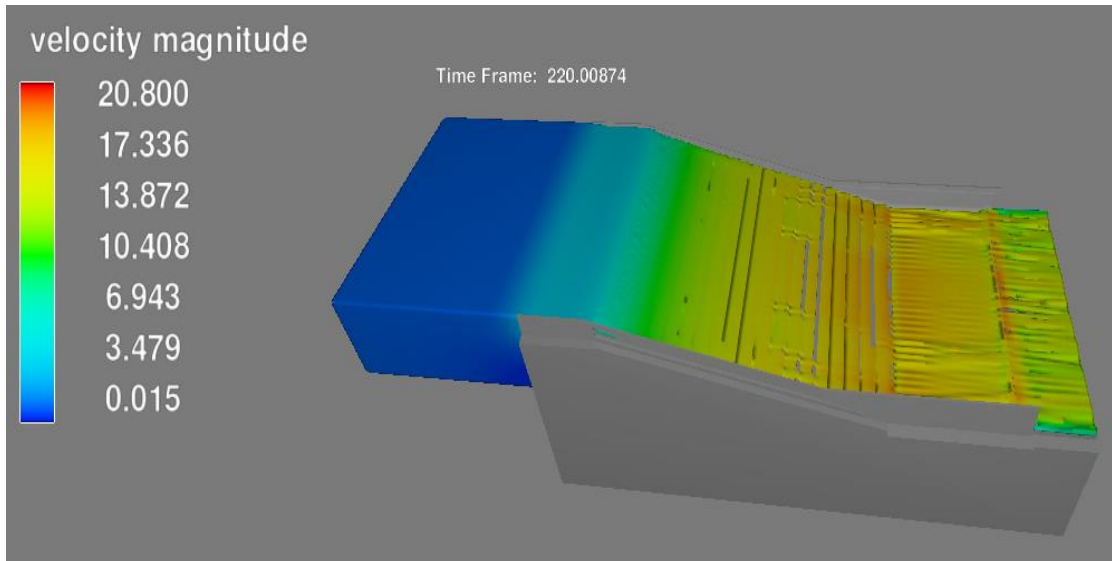

Figure 4.11 Velocity contour at 1589 Cumecs

In Figure 4.12, 1448 Cumecs of discharge has been passed through the chute spillway. The velocities are in the range of 20 m/s.

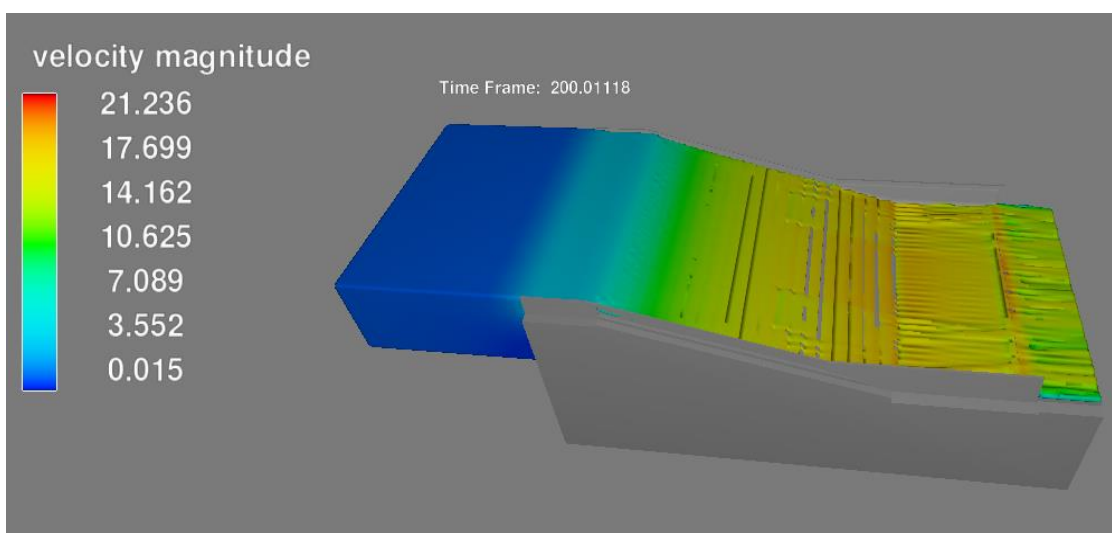

Figure 4.12 Velocity contour at 1448 Cumecs

In Figure 4.13, 1116 Cumecs of discharge has been passed through the chute spillway. The velocities are in the range of 19 m/s.

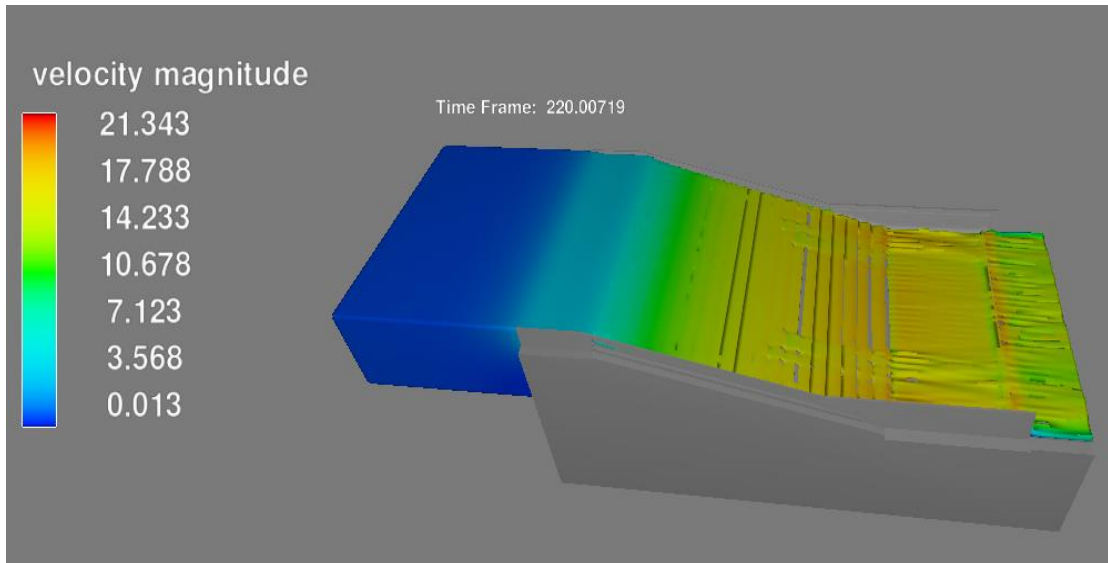

Figure 4.13 Velocity contour at 1116 Cumecs

In Figure 4.14, 974.7 Cumecs of discharge has been passed through the chute spillway. The velocities are in the range of 18 m/s.

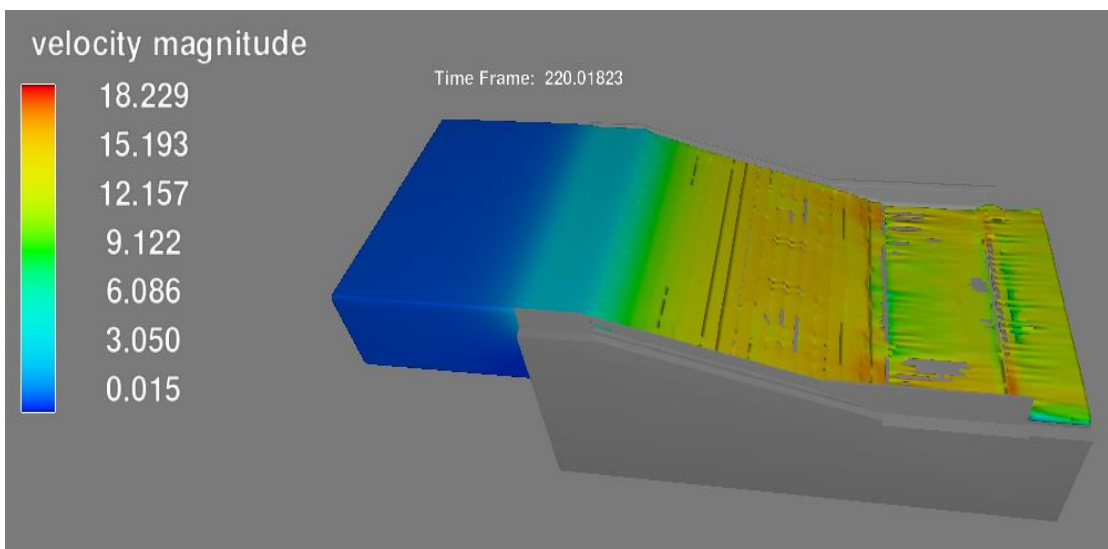

Figure 4.14 Velocity contour at 974.7 Cumecs

In Figure 4.15, 634.9 Cumecs of discharge has been passed through the chute spillway. The velocities are in the range of 17 m/s.

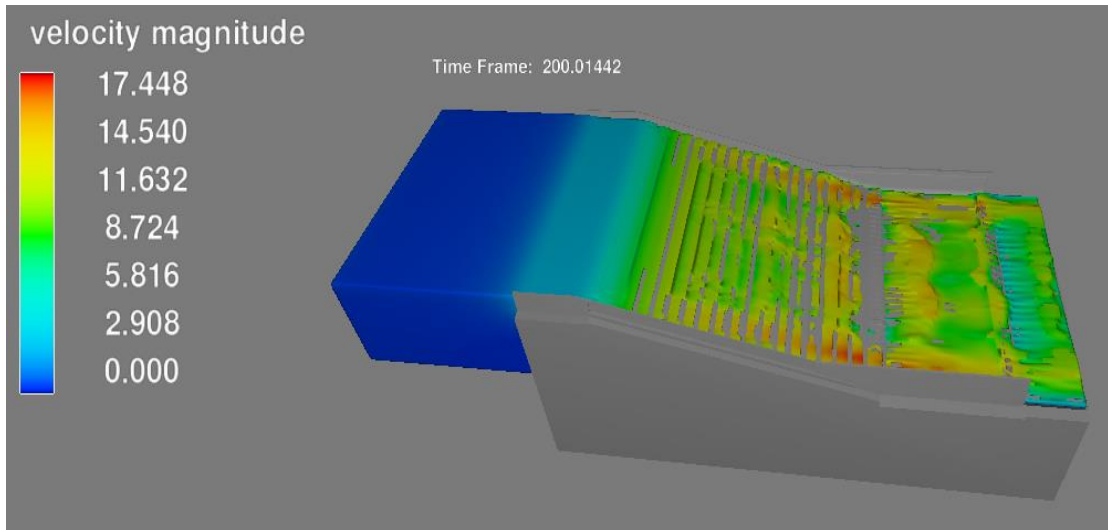

Figure 4.15 Velocity contour at 634.9 Cumecs

In Figure 4.16, 268.5 Cumecs of discharge has been passed through the chute spillway. The velocities are in the range of 12 m/s.

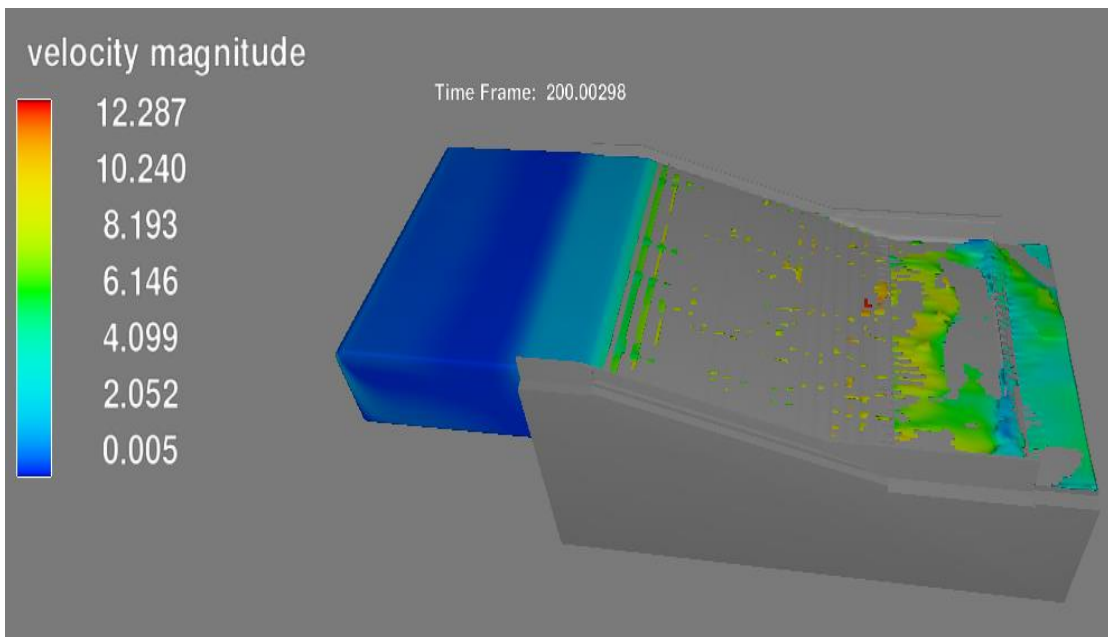

Figure 4.16 Velocity contour at 268.5 Cumecs

4.7.3 Pressure

Pressure fluctuation can be seen in the Figure 4.17 which tells that pressure is increasing or decreasing with the submergence ratio. The area of spillway where there is more water, the pressure is more and where water is lesser the pressure values are decreasing. This is because the pressure is directly related to the depth of water, the more the water the greater will be the pressure.

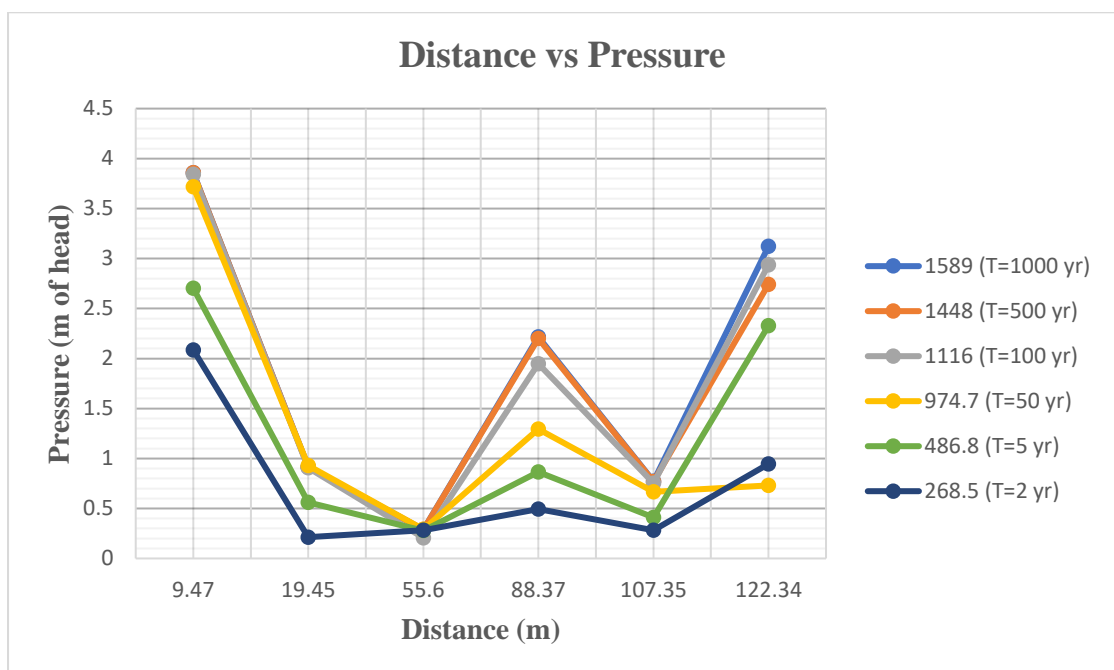

Figure 4.17 Pressure fluctuations

4.7.4 Turbulence Models

Turbulence intensity, turbulence kinetic energy and turbulence dissipation are shown in Table 4.2. This table is showing that with the decrease in the discharge values the turbulence values are decreasing with it due to the water submergence.

Table 4.2 Turbulence characteristics

Sr #	Discharge (Cumecs)	Turbulence Intensity (%)	Turbulent kinetic Energy ($\frac{m^2}{s^2}$)	Turbulence Dissipation
1	1589	1.95	4.770	1.73
2	1448	1.73	4.41	1.34
3	1116	1.34	4.24	0.58
4	974.7	1.34	3.71	0.45
5	634.9	1.09	3.23	0.08
6	268.5	0.8	2.33	0.0092

4.7.5 Bed Shear Stresses

Bed shear stresses are shown in the figure 4.18. The cross-sectional view is shown in figure on stilling basin at a distance of about 89.37 m at maximum discharge of 1589 Cumecs. From the figure it can be seen that the maximum stresses are shown at the center of the stilling basin and are minimum at both ends of the stilling basin.

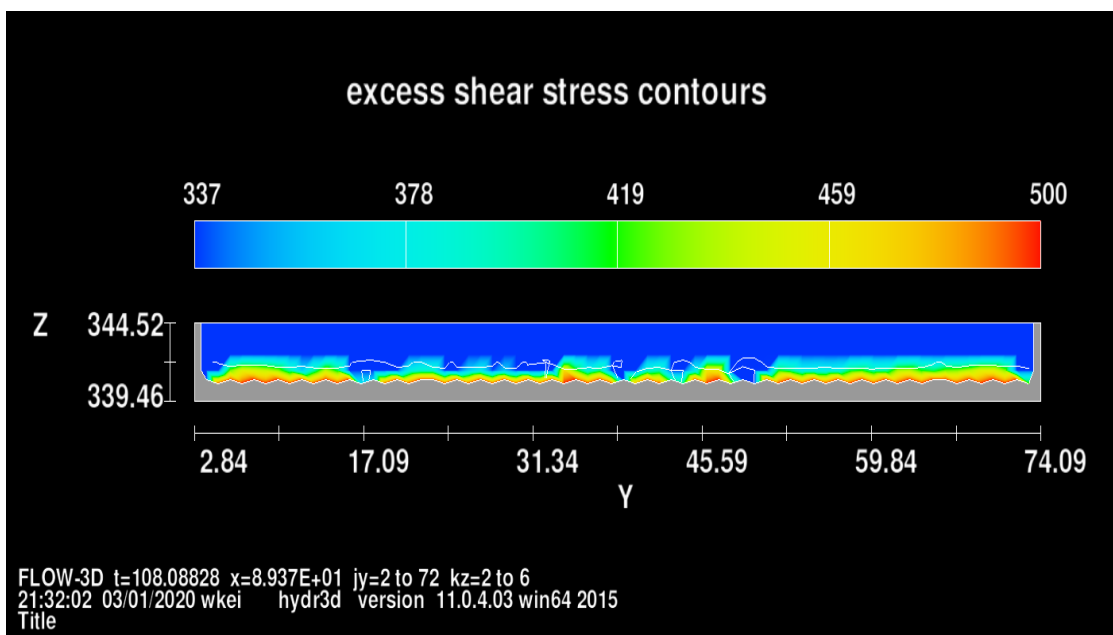

Figure 4.18 Cross sectional view for bed shear stresses

In figure 4.19, longitudinal view is shown of spillway at stilling basin for a discharge of 1589 Cumecs. As shown, shear stresses are minimum at the ends and are maximum at the center of the spillway with shows that geometry of spillway is correct.

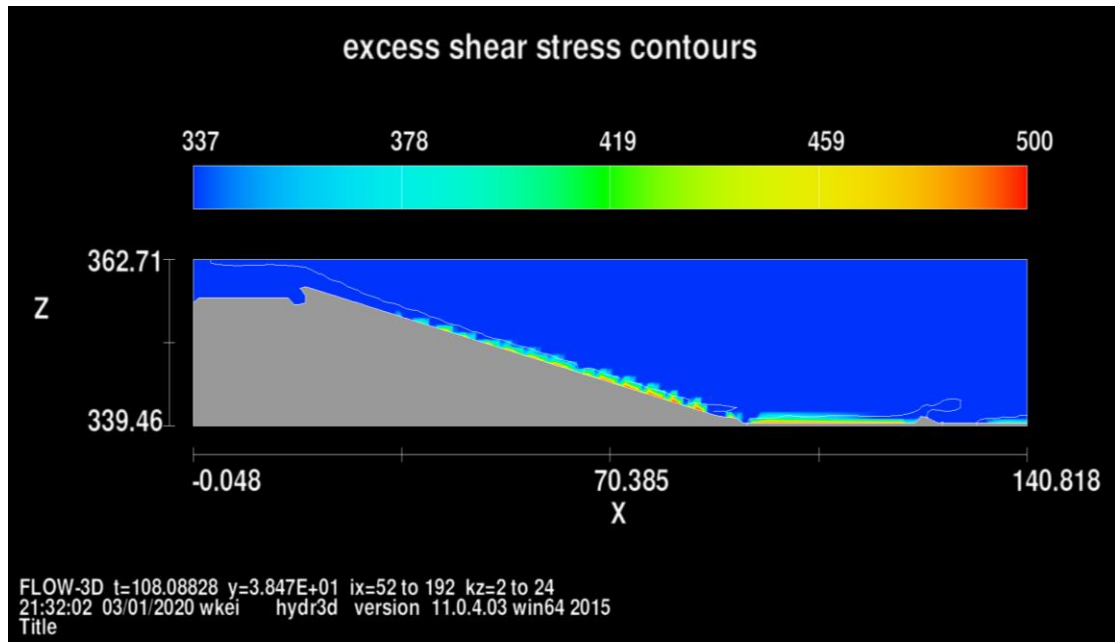

Figure 4.19 Longitudinal view for bed shear stresses

4.7.6 Cavitation

Cavitation can be checked if the absolute pressure is less than the vapor pressure. Vapor pressure is determined from the maximum temperature of the region. Maximum temperature for the Jehlum region is 49.2 °C from where the vapor pressure came out to be 88.45 torr (11793 Pa). Absolute pressure is determined when the atmospheric pressure is added to gauge pressure. Atmospheric pressure of Jehlum region is 1012 mb (101200 Pa). For the maximum discharge of 1589 Cumecs the gauge pressure is 18290 Pa on average. So, from the figures it is cleared that the absolute pressure is greater than vapor pressure so no cavitation phenomenon is happening in the spillway.

4.8 PERFORMANCE OF ENERGY DISSIPATION

Energy dissipation system of the Domeli dam spillway was checked at the start and at the end of the stilling basin for different discharges referring to Figure 4.20. The values of Froude number are significantly decreasing when moving from start of stilling basin i.e. chute blocks towards the end of the spillway i.e. end sills. Certain amount of energy is also dissipated which is calculated by following formula:

$$\Delta E = \left(y_2 + \frac{V_2^2}{2g} \right) - \left(y_1 + \frac{V_1^2}{2g} \right) \quad (4.2)$$

Where,

ΔE = Energy difference, Y_1 = Depth at 88.37 m , V_1 = Velocity at 88.37 m , Y_2 = Depth at 122.34 m, V_2 = Velocity at 122.34 m

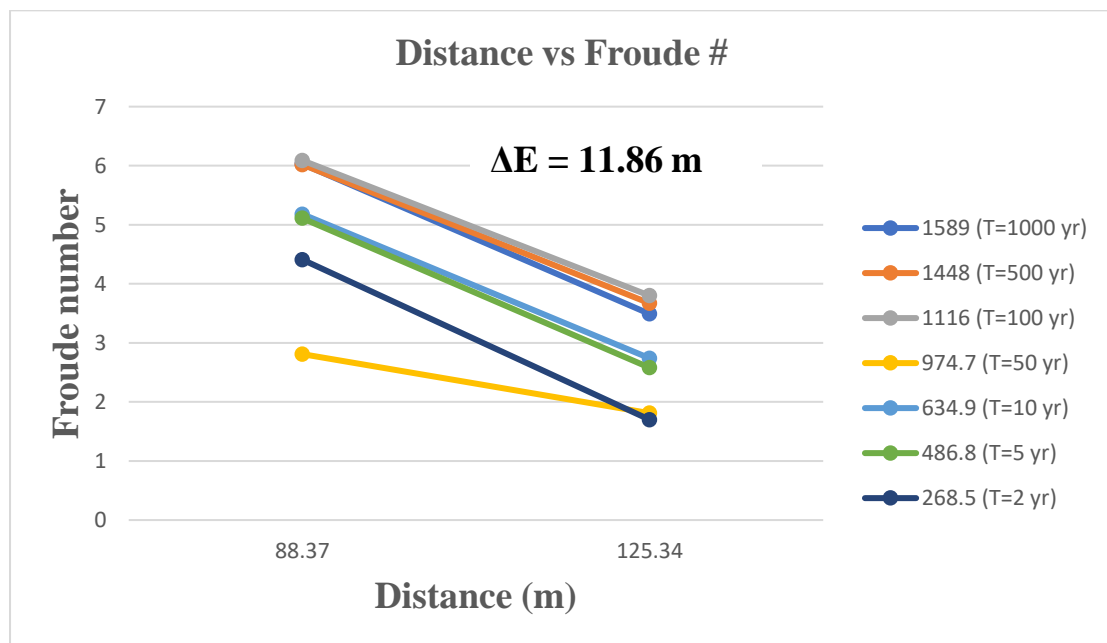

Figure 4.20 Energy dissipation

From Figure 4.21 it is concluded that 11.86 m of energy is dissipated in the case of 1589 Cumecs discharge which is corresponding to 1000 years return period. Stilling basin is efficient enough as it is dissipating energy of about 70%.

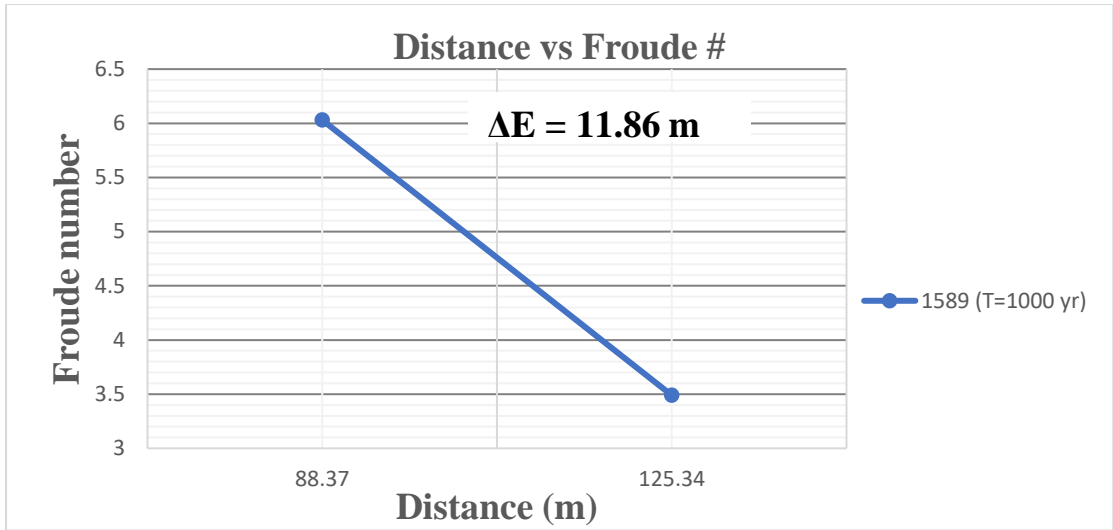

Figure 4.21 Energy dissipation at 1589 Cumecs

Chapter V

CONCLUSIONS & RECOMMENDATIONS

5.1 INTRODUCTION

Data was collected from different departments for the required time duration and then analysis of data was carried out. Firstly, rainfall frequency analysis was carried out, from which results were imported for flood analysis. These floods were computed using HEC-HMS. Hydrodynamic models for the spillway was carried out using Flow-3D model. Flow characteristics of spillway were simulated and sensitivity analysis was carried out using different mesh sizes.

5.2 CONCLUSIONS

- Computed floods corresponding to 2, 5, 10, 50, 100, 500 & 1000 years came out to be 268.5, 486.8, 634.9, 974.7, 1116, 1448 and 1589 cumecs, respectively.
- Flow-3D was well validated for flow depths. As the observed and simulated values have very close match and has a difference of about 8.5%.
- The values of hydraulic depth vary too much with the increase or decrease of mesh size which show that Flow-3D was sensitive to mesh size.
- Pressure fluctuation over spillway was inversely related to submergence.
- From the results it can be seen that with the decrease in the discharges, the values of flow depths also decreases.
- The energy dissipation system was found adequate as Froude Number is significantly decreasing over stilling basin.
- Rehabilitated spillway of Domeli dam has been found efficient enough as it is dissipating energy of about 70%.

- From the results it can be seen that the energy dissipation system is working properly, hydraulic shear stresses are in specified ranges, stilling basin is save regarding high flood values and cavitation phenomenon is not happening and also there is no design fault. So, it is concluded that the failure of spillway is not concerned with the above-mentioned reasons. The reason for its damage can be poor quality control, poorly compacted sub-grade and poor quality of construction.

5.3 RECOMMENDATIONS

- Rehabilitated spillway is recommended for appropriate energy dissipation. As the energy is adequately dissipating with a value of 11.86 m which is approximately 70%.
- Flow-3D model is recommended to simulate the flow characteristics over spillway.

5.4 FUTURE RECOMMENDATIONS

- Simulation of flow may be carried out using appropriate boundary conditions in Flow-3D model.
- In the present study, sediment transport modeling was not carried out. Hence it is recommended that sediment transport study may be added while 3D modeling.

REFERENCES

- Chanel, P. G., & Doering, J. C. (2008). Assessment of spillway modeling using computational fluid dynamics. *Canadian Journal of Civil Engineering*, 35(12), (pp. 1481-1485).
- Chanel, P. G., & Doering, J. C. (2007). An evaluation of computational fluid dynamics for spillway modelling. In 16th Australasian Fluid Mechanics Conference (AFMC) School of Engineering, The University of Queensland, (pp. 1201-1206).
- Fadaei-Kermani, E., & Barani, G. A. (2014). Numerical simulation of flow over spillway based on the CFD method. *Scientia Iranica. Transaction A, Civil Engineering*, 21(1), (pp. 91).
- Kim, S. D., Lee, H. J., & An, S. D. (2010). Improvement of hydraulic stability for spillway using CFD model. *International Journal of Physical Sciences*, 5(6), (pp. 774-780).
- Kim, D. G., & Park, J. H. (2005). Analysis of flow structure over ogee-spillway in consideration of scale and roughness effects by using CFD model. *KSCE Journal of Civil Engineering*, 9(2), (pp. 161-169).
- Maghrebi, M., Alizadeh, S., & Lotfi, R. (2012). Numerical Simulation of Flow Over Rectangular Broad Crested Weir (Real case study). In the First International Conference on Dams and Hydropower.
- Novak, P., Moffat, A. I. B., Nalluri, C., & Narayanan, R. (2017). *Hydraulic structures*. CRC Press.
- Nohani, E. (2015). Numerical Simulation of the Flow Pattern on Morning Glory Spillways. *International Journal of Life Sciences*, 9(4), (pp. 28-31).
- Parsaie, A., Haghiabi, A. H., & Moradinejad, A. (2015). CFD modeling of flow pattern in spillway's approach channel. *Sustainable Water Resources Management*, 1(3), (pp. 245-251).
- Rady, R. M. A. E. (2011). 2D-3D modeling of flow over sharp-crested weirs. *J. Appl. Sci. Res*, 7(12), (pp. 2495-2505).
- Zhenwei, M. U., Zhiyan, Z., & Tao, Z. H. A. O. (2012). Numerical simulation of 3-D flow field of spillway based on VOF method. *Procedia Engineering*, 28, (pp. 808-812).